

THE NUBIAN MASON'S MANUAL

Professional rules for implementing
the Nubian Vault concept

Version 2 (2018)



FOREWORD

This manual, produced and distributed by the Nubian Vault Association (AVN), covers the rules and basic technical recommendations for the construction of Nubian vault (NV) buildings in those countries where the NV market is developing, and, more generally, in Sahelian zones.

The use of the NV concept in more humid and tropical climates has not been validated by AVN, and would need to be tested experimentally in situ before any adaptation.

The information in this manual is based on the wealth of experience acquired by AVN and by NV masons since the start of AVN's programme in the year 2000, and is based on precise technical constraints proposed by AVN to guarantee the safety of NV buildings, and to ensure optimal transfer of NV know-how.

This manual is aimed principally at NV artisans and masons, completing, reinforcing and confirming the skills acquired on NV construction sites. It also provides supporting material for the training of new apprentices.

It must not be considered as an independent "construction methodology" and can in no way replace on-site training provided by experienced NV masons. Hence the use of this document alone can in no case guarantee a correct implementation of the NV technique and the quality of any constructions. The distribution and use of this document does not engage AVN's responsibility for any defects or accidents on NV building sites.

Thomas Granier

AVN Founder and Director General

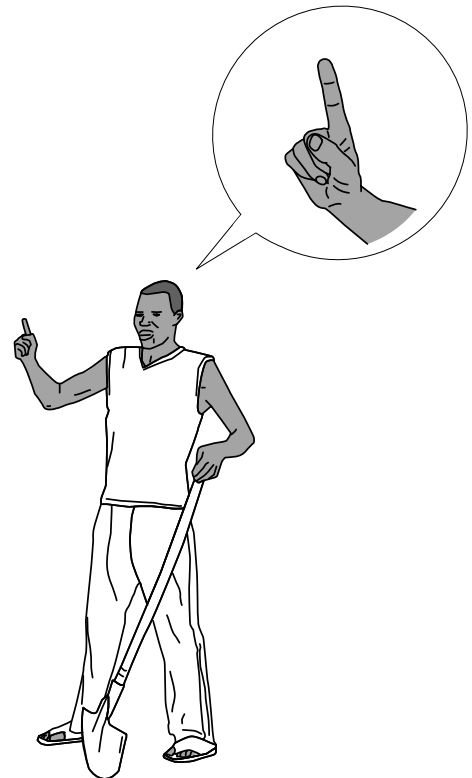

CONTENTS

- 0 Contents
- 0 Elements of a nubian vault building

BASIC NOTIONS

1 - Building materials

- 1.1 General points (BASE)
- 1.2 Special bricks (BASE)
- 1.3 ★ Selection of soil: basic tests (ADDITIONAL)
- 1.4 Preparation of the soil (BASE)
- 1.5 ★ Soil analysis table (ADDITIONAL)
- 1.6-A Brick dimensions (BASE)
- 1.6-B Moulds for large bricks (BASE)
- 1.6-C Moulds for small bricks (BASE)
- 1.7 Production of bricks (BASE)
- 1.8 Quality control of large bricks (BASE)
- 1.9 Various cement mixtures (BASE)

2 - Equipment

- 2.1 Construction site equipment (BASE)
- 2.2 Mason's tools & guide cable (BASE)

3 - Rules for siting & sizing nubian vaults

- 3.1 Choosing a site (BASE)
- 3.2 Ground levels & drainage (BASE)
- 3.3 Vault dimensions (BASE)
- 3.4 Height of vault baseline (BASE)

DIMENSIONNEMENTS ET MISE EN OEUVRE DU GROS OEUVRE

4 - Foundations

- 4.1 Foundations of load-bearing walls, gable walls, dividing walls & partitions (BASE)
- 4.2 Marking out the site (BASE)
- 4.3 Excavating the trenches (BASE)
- 4.4 Foundations in stone & earth mortar (BASE)
- 4.5 ★ Rammed earth foundations (ADDITIONAL)

5 - The walls

- 5.1 Wall thickness (BASE)
- 5.2 Checking alignment & verticality (BASE)
- 5.3 Basic principles of bond patterns (BASE)
- 5.4 Basic standard bond patterns (BASE)
- 5.5 Variants of the standard bond pattern (BASE)
- 5.6 ★ Bond patterns for mixed brick walls (ADDITIONAL)
- 5.7 ★ Production & bonding of stony bricks (ADDITIONAL)
- 5.8 ★ Reinforced wall base (ADITIONNELLE)
- 5.9 ★ Concrete reinforced wall base (ADDITIONAL)
- 5.10 Ventilation of the gable walls (BASE)

6 - Openings

- 6.1 Rules for wall openings (BASE)
- 6.2 Rules for wall openings (BASE)
- 6.3 Bond patterns for doors & windows (BASE)
- 6.4 Bond patterns for alcoves (BASE)
- 6.5 ★ Rules for making archways in gable walls (ADDITIONAL)
- 6.6 ★ Construction of archways in gable walls (ADDITIONAL)
- 6.7 ★ Concrete block arcades in load-bearing walls (ADDITIONAL)
- 6.8 ★ Reinforced concrete post & beam doorways in load-bearing walls (ADDITIONAL)

7 - The compass cable

- 7.1 The compass cable - fabrication (BASE)
- 7.2 The compass cable - installation (BASE)

8 - Arches

- 8.1 Formwork for arches (BASE)
- 8.2 Building the arches (BASE)

9 - The vault

- 9.1 Starting the vault (BASE)
- 9.2 Progressing the vault (BASE)
- 9.3 Closing the vault (BASE)

10 - Vault infill

- 10.1 Loading the vault (BASE)
- 10.2 Loading the vault (BASE)

11 - The roof

- 11.1 Orientation of the slope (pitch) of the roof (BASE)
- 11.2 Masonry roof pitch (BASE)
- 11.3 Gutters (BASE)
- 11.4 Waterproofing (BASE)
- 11.5 ★ Encased rainwater downpipes (ADDITIONAL)

12 - Parapets

- 12.1 ★ Protection with cement slabs (ADDITIONAL)
- 12.2 ★ Reinforced concrete protection (ADDITIONAL)
- 12.3 Balustrades (BASE)
- 12.5 ★ Metal or timber balustrades (ADDITIONAL)

13 - Exterior staircases

- 13.1 ★ Examples of exterior staircases (ADDITIONAL)
- 13.2 ★ Dimensions and tracing (ADDITIONAL)
- 13.3 ★ Constructing the staircases (ADDITIONAL)

14 - Internal staircases

- 14.1 ★ One stage internal staircase (ADDITIONAL)
- 14.2 ★ Two stage internal staircase (ADDITIONAL)

15 - Upper storey vault

- 15.1 ★ Upper storey vault (ADDITIONAL)
- 15.2 ★ Upper storey masonry (ADDITIONAL)
- 15.3 ★ Adding an upper storey (ADDITIONAL)
- 15.4 ★ Openings in upper storeys (ADDITIONAL)

16 - Extensions

- 16.1 Extending a vault (BASE)
- 16.2 Adding a side vault (BASE)

FINISHING WORKS

17 - Minor masonry works

- 17.1 Thick masonry partition walls (BASE)
- 17.2 Masonry shelves (BASE)
- 17.3 ★ Lightweight partitions (ADDITIONAL)

18 - Joinery

- 18.1 ★ Window sills (ADDITIONAL)
- 18.2 ★ Fitting standard windows (exterior) (ADDITIONAL)
- 18.3 ★ Fitting with a reinforced concrete sill (ADDITIONAL)

19 - Electrical works

- 19.1 ★ Cable ducts and channels (ADDITIONAL)
- 19.2 ★ Ceiling lights and fans (ADDITIONAL)

20 - Plumbing

- 20.1 ★ Waste water pipe work (ADDITIONAL)
- 20.2 ★ Upper storey plumbing (ADDITIONAL)

21 - Floors

- 21.1 ★ Examples of floor treatments (ADDITIONAL)
- 21.2 ★ Cement screed and tiling (ADDITIONAL)
- 21.3 ★ Lowering internal floor level (ADDITIONAL)

22 - Renders

- 22.1 Introduction (BASE)
- 22.2 Surface preparation (BASE)
- 22.3 Traditional earth based renders (BASE)
- 22.4 ★ Bitumen render for external walls (ADDITIONAL)
- 22.5 ★ Bitumen render for roofs (ADDITIONAL)
- 22.6 ★ Sand-cement render for external walls of stony bricks (ADDITIONAL)
- 22.7 ★ Sand-cement render for interior walls (ADDITIONAL)
- 22.8 ★ Wall tiling (ADDITIONAL)

24 - Paint

- 24.1 Interior whitewash and paints (BASE)
- 24.2 ★ External paintwork (ADDITIONAL)

0

BASIC NOTIONS

ELEMENTS OF A NUBIAN VAULT BUILDING

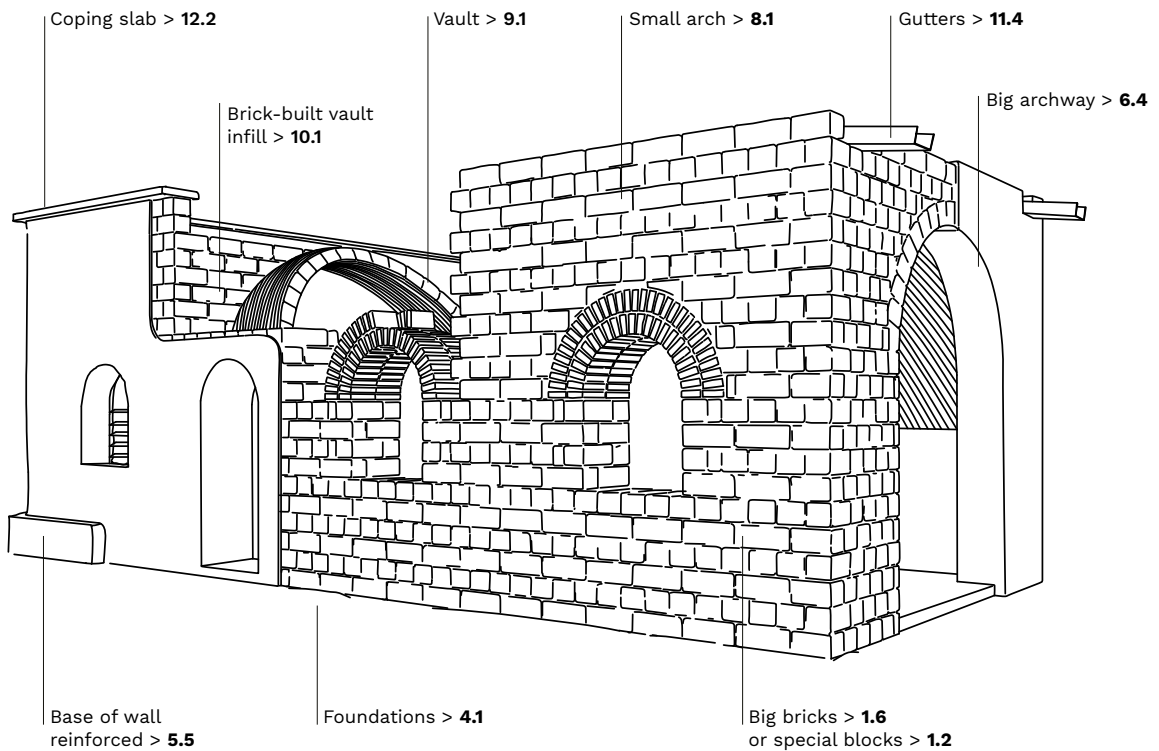
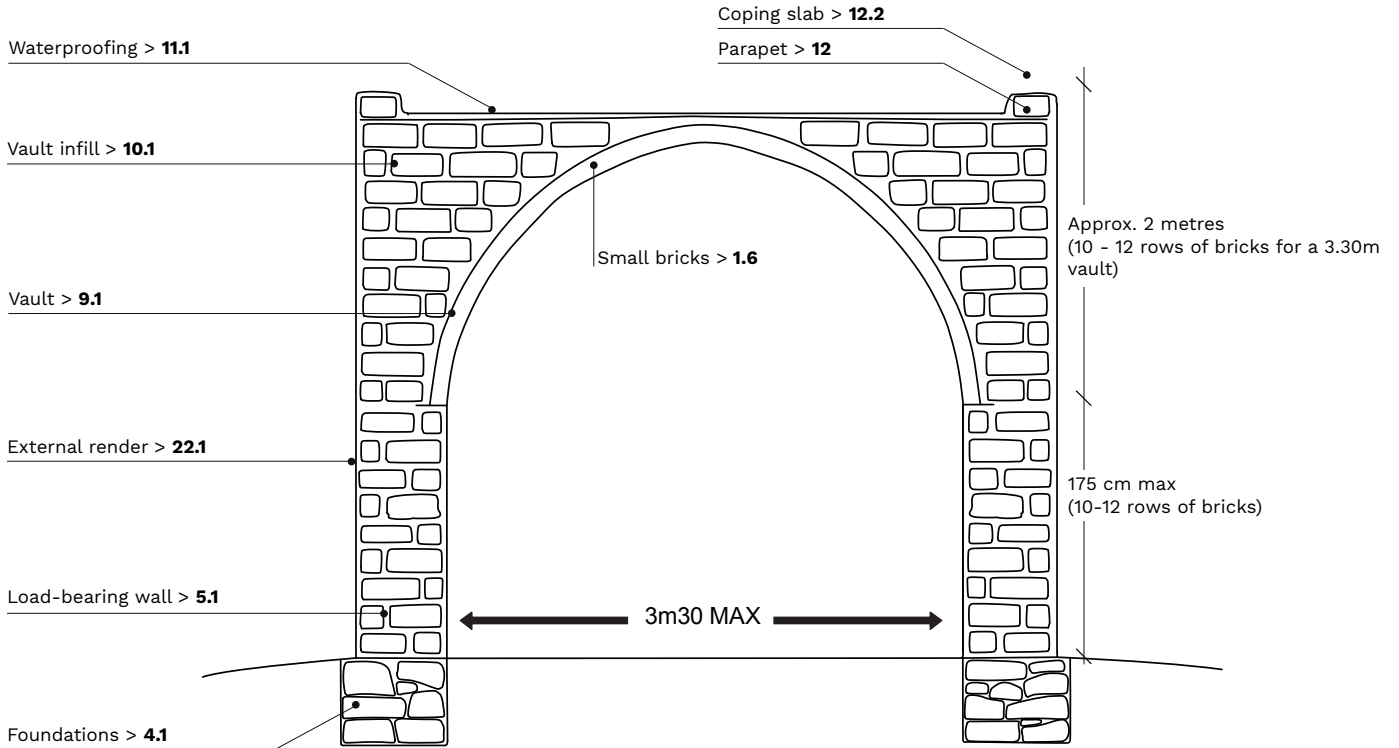

1.1

BUILDING MATERIALS

GENERAL POINTS

1

Earth for building

Used for making bricks, for mortar (banco), and for some renders. The earth must be neither too sandy, nor too clayey.

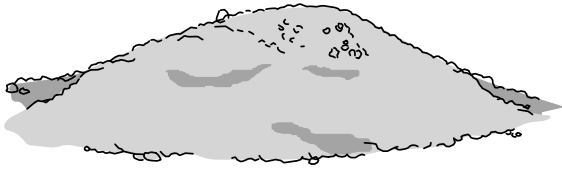

2

Rocks

Used in foundations (blocking masonry). Can be replaced by rammed earth if unavailable.

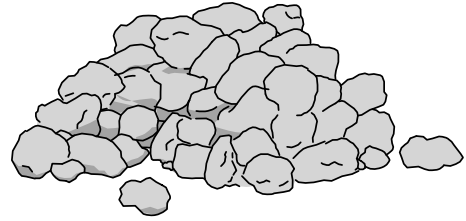

3

Wall bricks

Mud (adobe) bricks made in wooden moulds and dried in the sun. Recommended dimensions for correct wall bonding are 38x17x15cm with 4cm vertical joints, but other dimensions are possible.

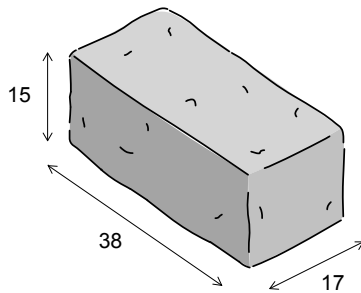

4

Vault and arch bricks

Small mud (adobe) bricks made in wooden moulds and dried in the sun. Dimensions are 25x15x5cm. The earth used must be of high quality. Generally made on-site, under the supervision of a head mason.

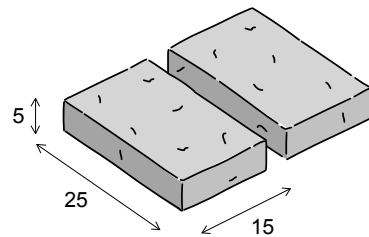

5

Plastic or rubber sheet

Helps to weatherproof the roof (with a covering layer of earth mortar); can also be used as a damp proof course at the base of walls and under the floor slab.

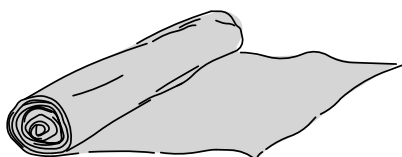

6

Water

Required in large quantities throughout construction.

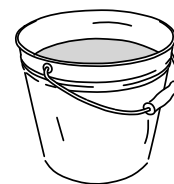

1.2

BUILDING MATERIALS SPECIAL BRICKS

If the funds and materials are available, it is possible to use other types of bricks for the external wall surfaces and other critical parts (base of walls, parapets...). These special bricks include:

- Stony bricks (mud bricks with encrusted stones) to which a cement render will adhere > 5.7
- Cut laterite bricks (or stone or concrete blocks) which can be rendered.

As a general rule, these bricks and blocks should have the same dimensions as the mud bricks used in the walls.

1
Stony bricks
> 5.7 / > 22.6

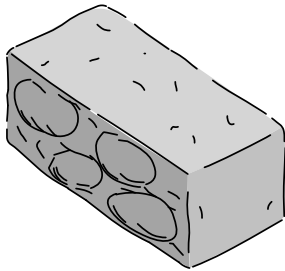

2
Cut laterite bricks
(mainly in Burkina Faso)

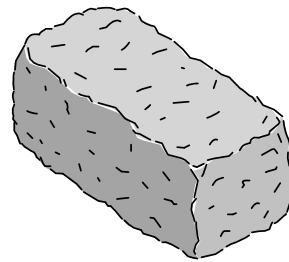

3
Solid concrete block

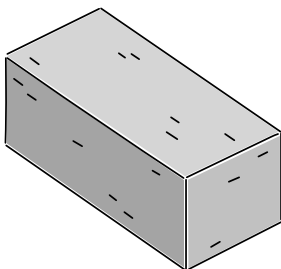

4
Stone block

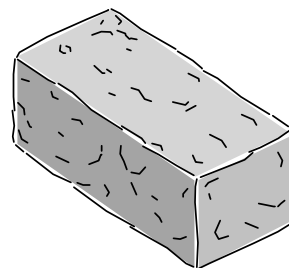

1.3 ★ AD

BUILDING MATERIALS

SELECTION OF SOIL: BASIC TESTS

As well as the specific tests listed here, it's important to stress that soil needs to be observed, handled, even tasted. Such tests are very important and, with some acquired experience, allow you to recognise the principal features of a sample of soil: sandy, silted, clayey, organic.

The soil must be chosen with great care, especially in zones where there is less and less traditional earth construction and the skills are being lost. The soil tests should always be carried out by the site foreman, and unsuitable soil must be rejected.

PHASE 2

1.4

BUILDING MATERIALS

PREPARATION OF THE SOIL

The soil should be soaked [1] and trampled [2] at least 24 hours before use, so it is thoroughly moistened. The procedure should be repeated several times to obtain a good quality banco for making both the bricks and the mortar.

1
Wet the soil

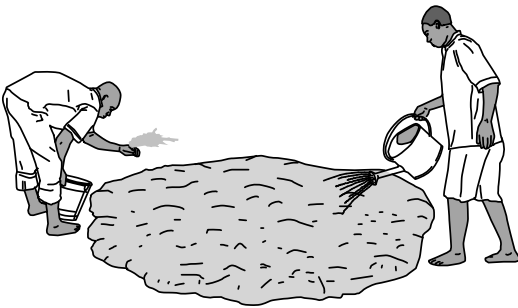

2
Trample on the moist soil



3
Wait 24 hours

Advice: cover with a tarpaulin to facilitate the work and prevent drying.

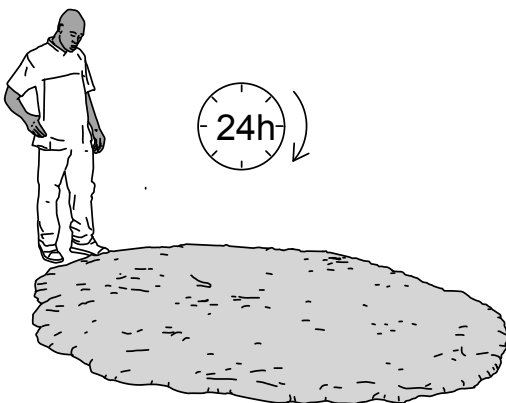

4
Trample again

Remember to add more water.



1.5 ★ AD
BUILDING MATERIALS
SOIL ANALYSIS TABLE

PHASE 2

1.6 - A

BUILDING MATERIALS

BRICK DIMENSIONS

The large bricks used for the walls and the small bricks for the arches and vaults are of different sizes and have to be made in different moulds.

Double or triple moulds can be used for the small bricks, but single ones are better for the large bricks.

REMEMBER:

When mud dries, shrinkage occurs depending on the type of soil. Take care!

1

Large banco bricks

A brick and its wooden mould:

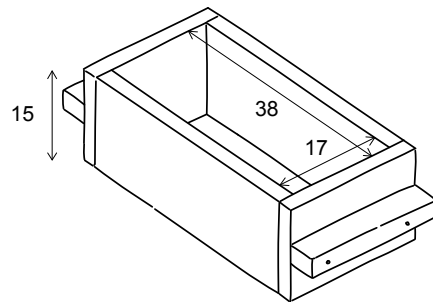
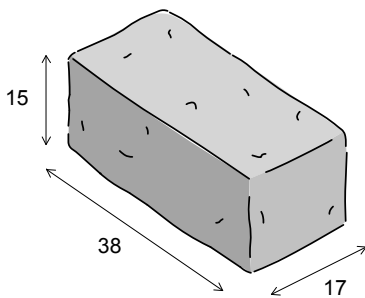

2

Small banco bricks for the vault

The bricks in their wooden mould:

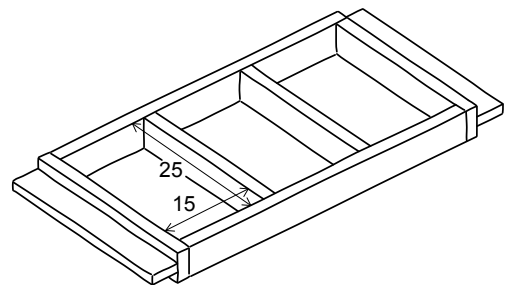
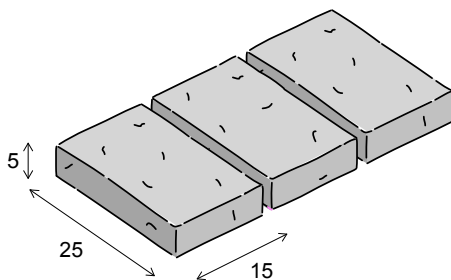

1.6 - B
BUILDING MATERIALS
MOULDS FOR LARGE BRICKS

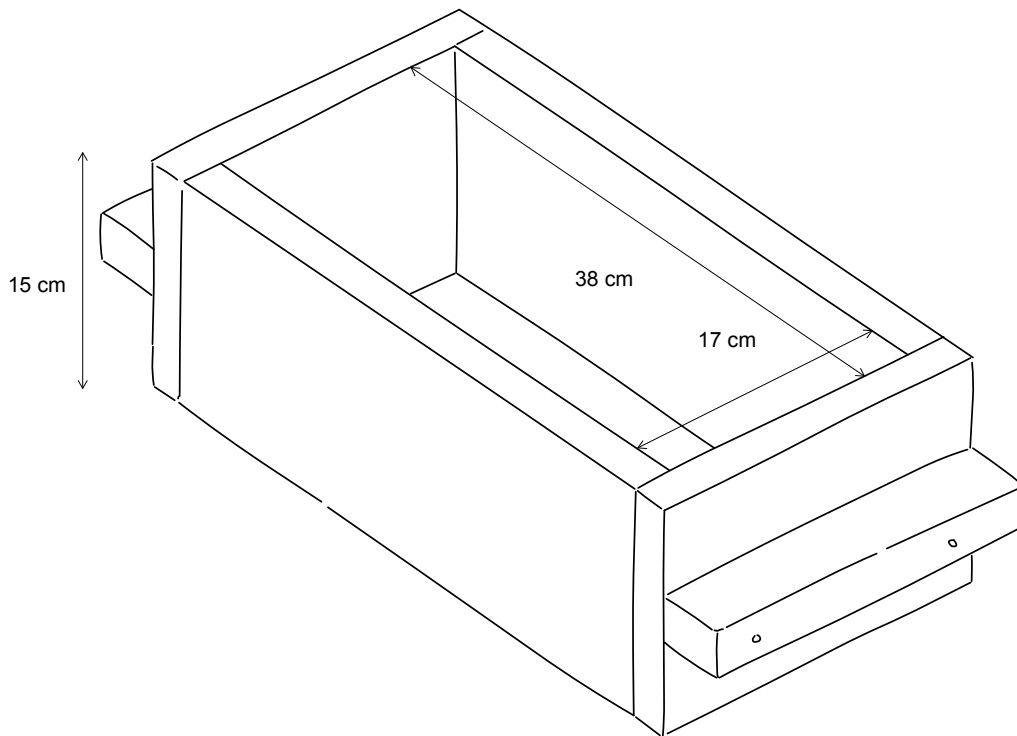

1.6 - C

BUILDING MATERIALS

MOULDS FOR SMALL BRICKS

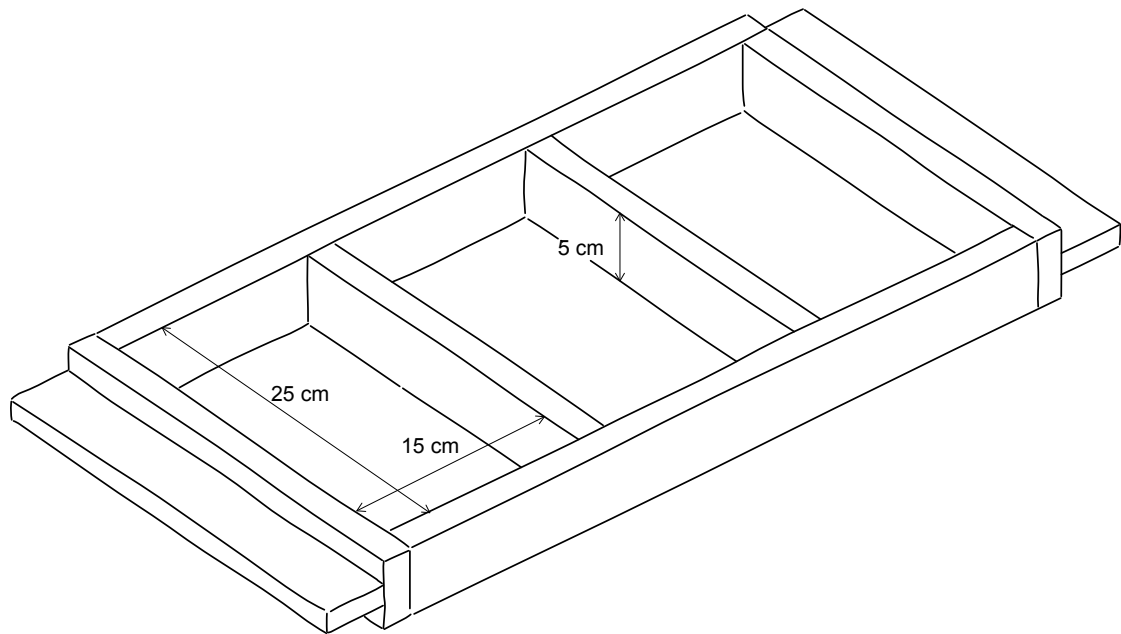

1.7

BUILDING MATERIALS

PRODUCTION OF BRICKS

(large and small)

1

Cleaning and preparation of the ground

so as to obtain a surface as smooth and clean as possible.



2

Moulding the bricks

Drying time for the large bricks is at least four days.

Average drying time for the small bricks is at least two days.

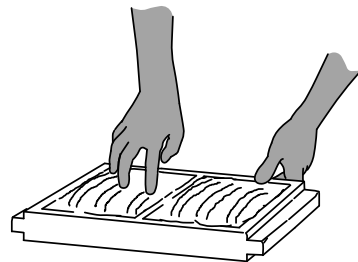
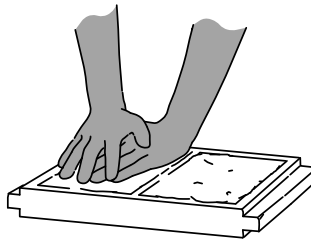
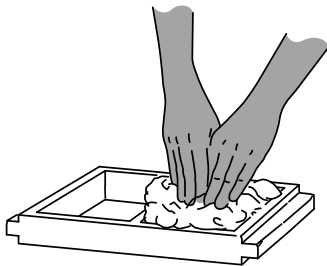
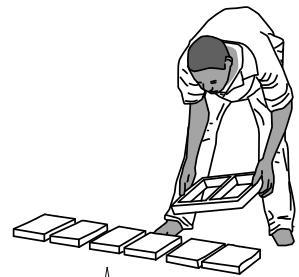
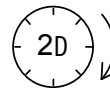
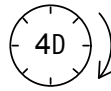
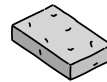
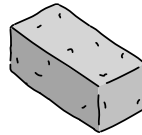

Set the mould on the ground; fill it with mud; smooth the surface; lift off the mould carefully. The surface of the small bricks can be roughened to allow for better adhesion when building the vault.

3

After they have dried lying flat, stack the bricks on end.

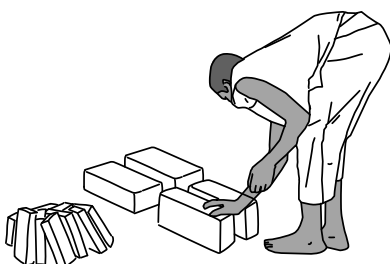

4

Scraping and cleaning up the bricks.



1.8

BUILDING MATERIALS

QUALITY CONTROL OF LARGE BRICKS

It is essential that the bricks be made with great care. When lots of ready made and dried bricks are purchased, the site foreman must test their strength and, if the results are doubtful, refuse to accept poor quality bricks for use in the main structure (although they could be used for less critical parts, such as infill for loading the vault).

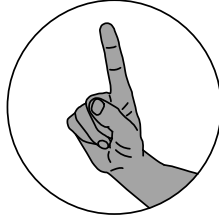

TEST FOR BRICK STRENGTH:

A person of average weight stands on a brick placed on two other bricks 30 cm apart: the brick must not break!

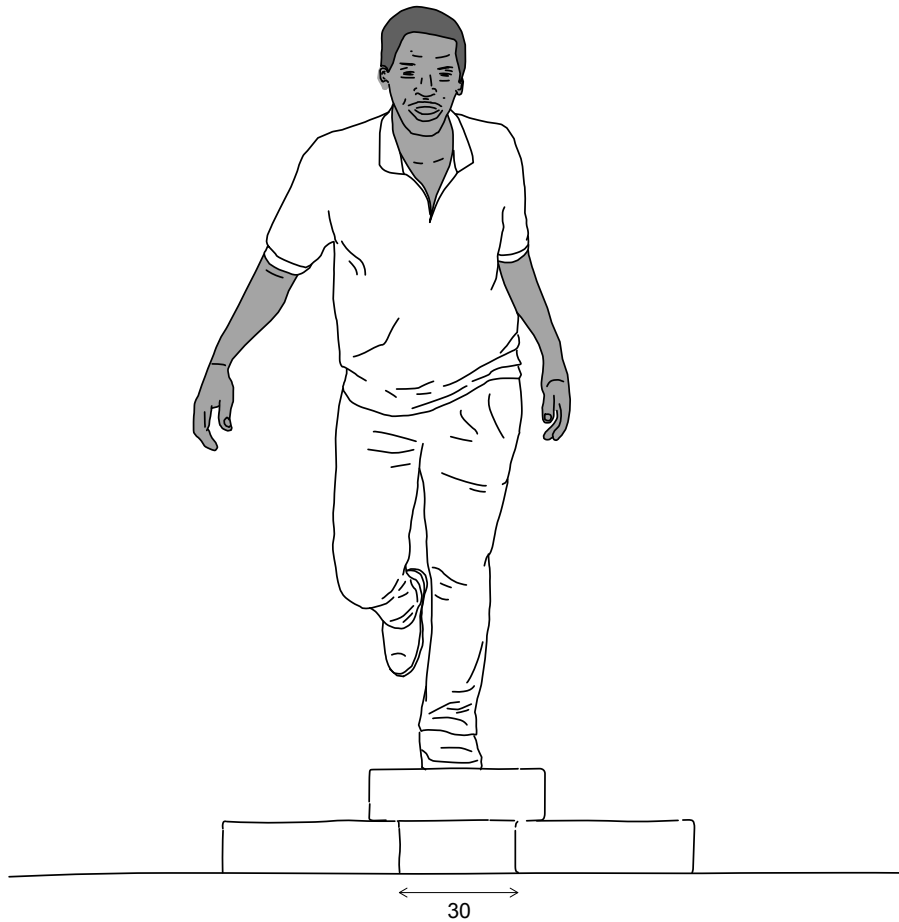





1.9

BUILDING MATERIALS

VARIOUS CEMENT MIXTURES

CEMENT DOSING FOR CONCRETE STRUCTURES:

	Cement 	Fine sand 	Gravel 	Water 
Blinding concrete 150Kg/m ³	50 kg	200 litres (3 wheelbarrows 60 l + 2 buckets 10 l)	280 litres (4 wheelbarrows 60 l / 4 buckets 10 l)	25 litres (2,5 buckets 10 l)
Concrete for Cyclopean footings and small works (coping slabs ...) 250 kg/m ³	50 kg	120 litres (2 wheelbarrows 60 l)	250 litres (4 wheelbarrows 60 l + 1 bucket 10 l)	25 litres (2,5 buckets 10 l)
Solid concrete (floor slabs, concrete blocks...) 300 kg/m ³	50 kg	90 litres (1,5 wheelbarrows 60 l)	120 litres (2 wheelbarrows 60 l)	25 litres (2,5 buckets 10 l)
Reinforced concrete (footings, posts, beams...) 350 kg/m ³	50 kg	70 litres (1 wheelbarrow 60 l + 1 bucket 10 l)	100 litres (1,5 wheelbarrows 60 l + 1 bucket 10 l)	25 litres (2,5 buckets 10 l)
Mortar 400 kg/m ³	50 kg	125 litres (2 wheelbarrows 60 l + 0,5 bucket 10 l)	-	30 litres (3 buckets 10 l)

2.1

EQUIPMENT

CONSTRUCTION SITE EQUIPMENT



Shovel

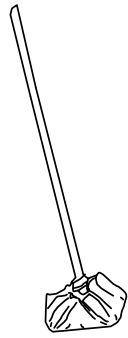

Tamper

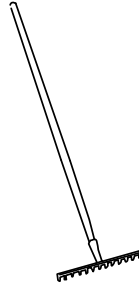

Rake



Bucket

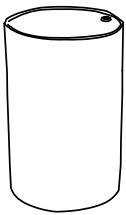

Barrel



Large hoe

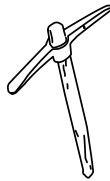

Pickaxe

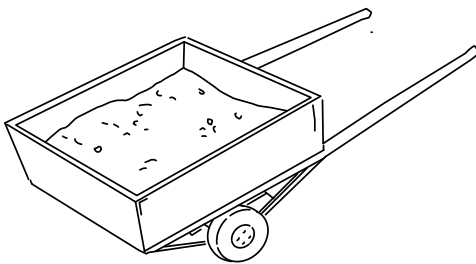

Cart

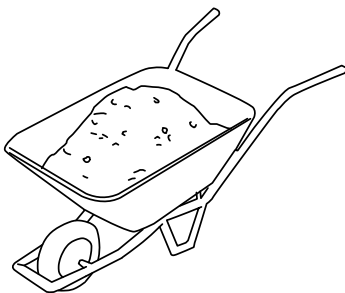

Wheelbarrow

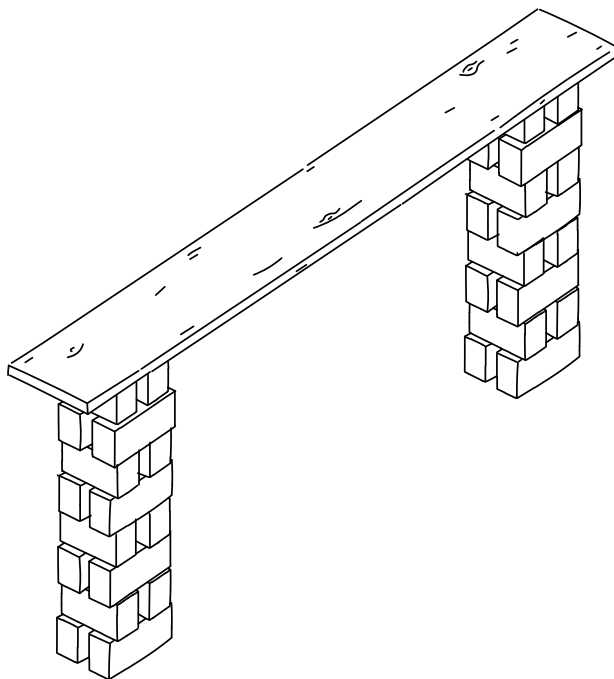

Scaffolding planks

2.2

EQUIPMENT

MASON'S TOOLS & GUIDE CABLE

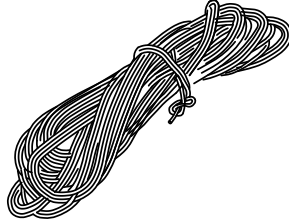

Rope

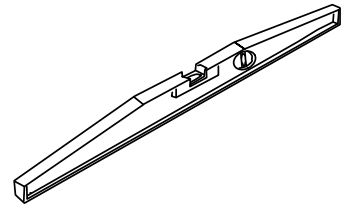

Spirit level

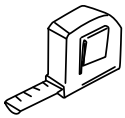

Measuring tape

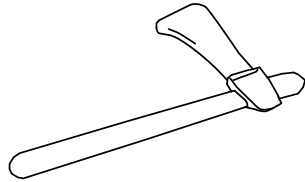

Axe

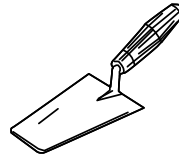

Trowel

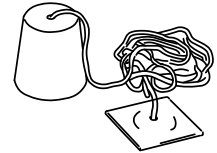

Plumb line

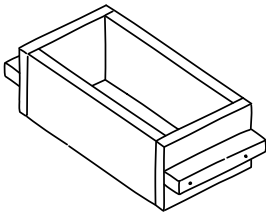

Mould for large bricks > 1.6

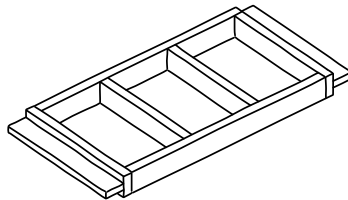

Mould for small bricks > 1.6

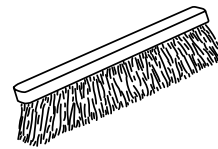

Brush

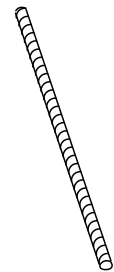

Stakes (rebar)

Tools for making the guide cable

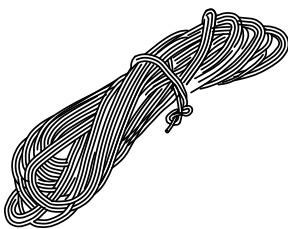

Rope



Rings

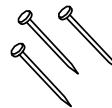

Nails

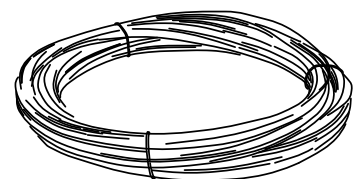

Steel wire

3.1

RULES FOR SITING & SIZING NUBIAN VAULTS

CHOOSING A SITE

Examine the terrain before starting construction.
Never build in depressions or damp ground
where there is stagnant water.

1

Good sites and a poor site

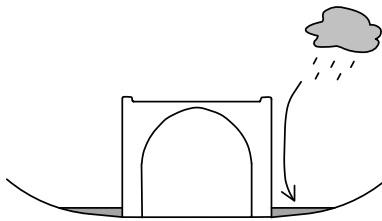
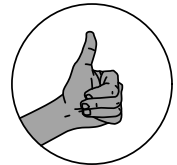
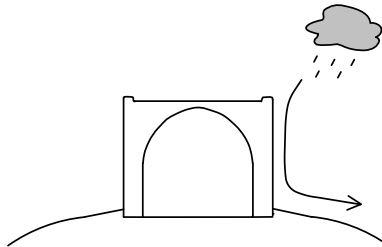
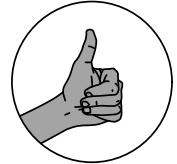
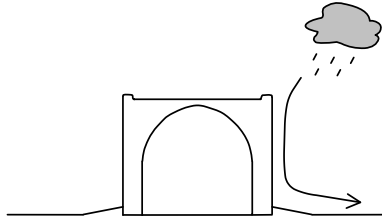

2

Plan ahead for later extensions and check for potential obstacles:
site boundaries, trees, ditches, disused wells...

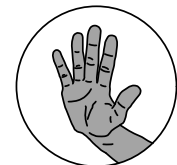
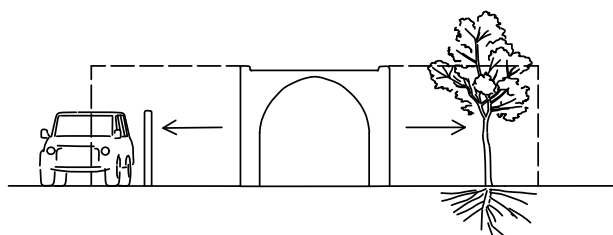
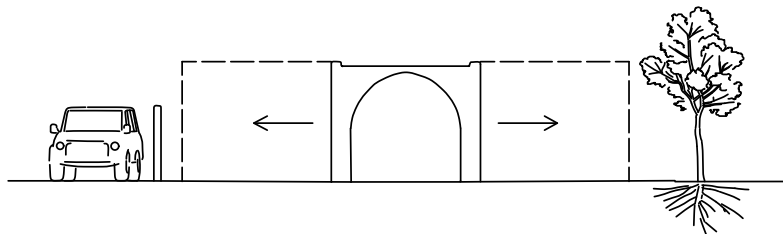

3.2

RULES FOR SITING & SIZING NUBIAN VAULTS

GROUND LEVELS & DRAINAGE

Protect the vault from water by making clean rammed earth slopes at its base.

REMINDER:
Never dig out the earth near the site,
even for making bricks or mortar.

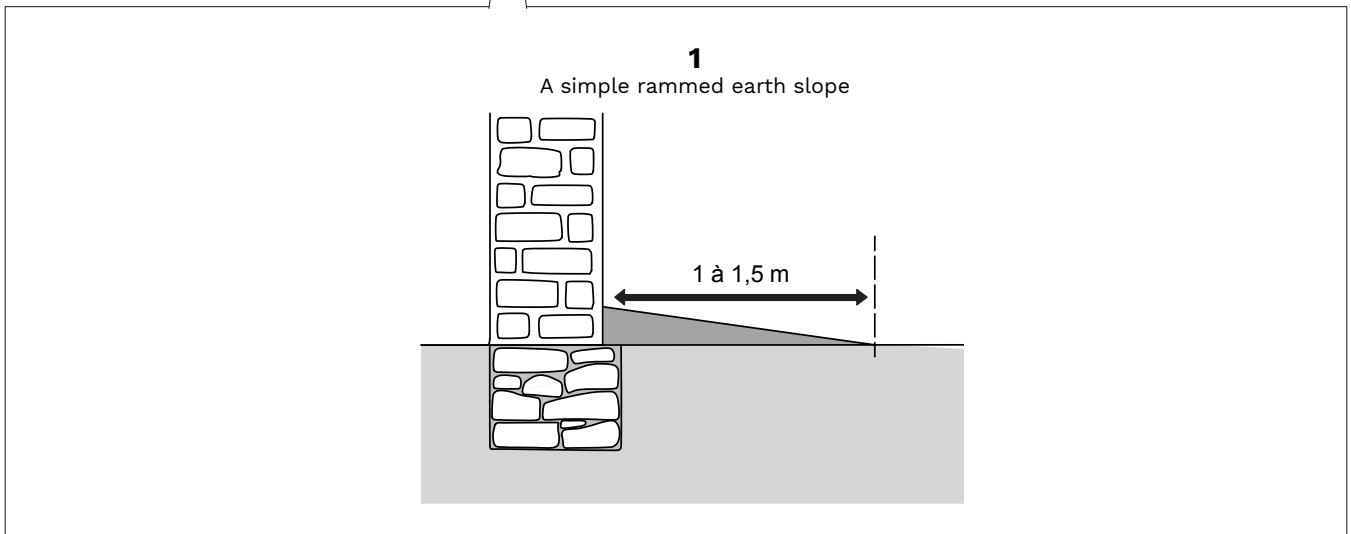
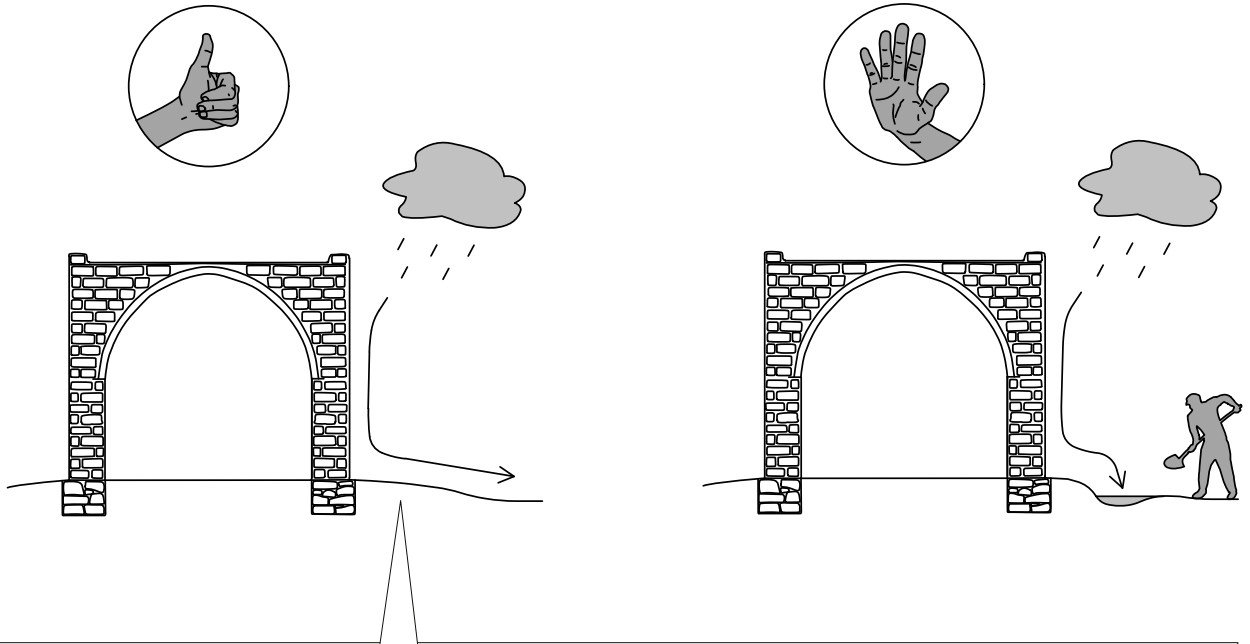

FOR ENCLOSED SITES:

Rainwater must be made to drain away from the site.
Make openings in the base of the enclosure wall so that water drains
into the street. The ground level of the site must be higher than that
of the street.

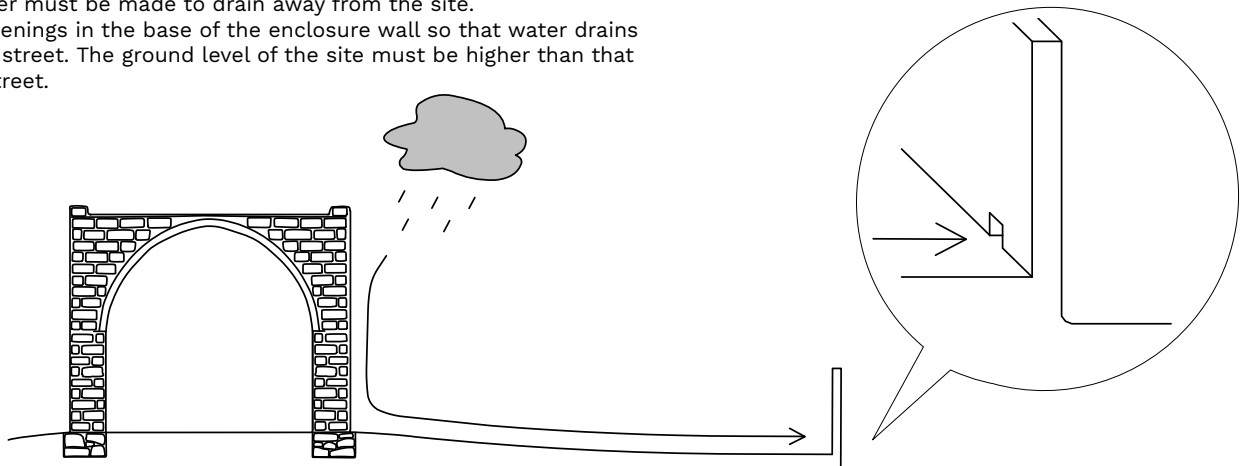

3.3

RULES FOR SITING & SIZING NUBIAN VAULTS

VAULT DIMENSIONS

1

Before marking out the site, the mason must agree the interior dimensions of the vault(s) with his client.

THE WIDTH MUST NOT EXCEED 3m30

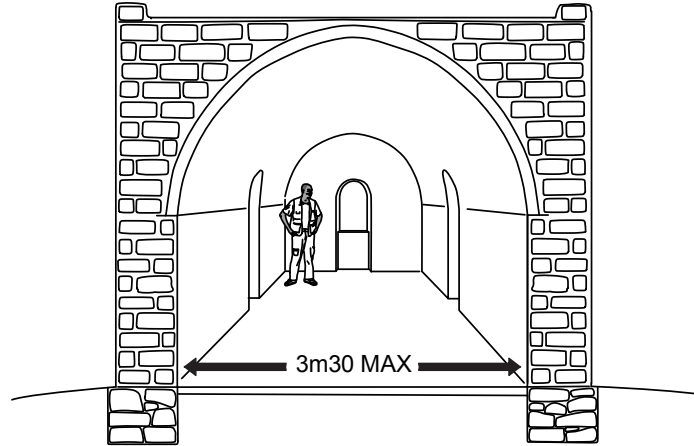

2

By reducing the vault width to 2m90, the client can make savings up to 30% in the construction materials needed.

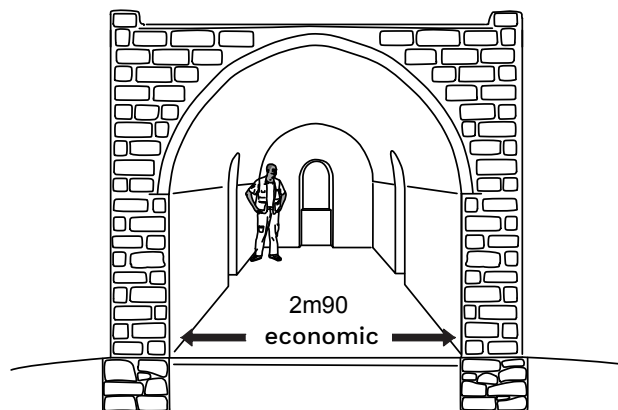

3

The length can vary up to a maximum of 12m.
It is advisable to include a dividing wall every 8m.

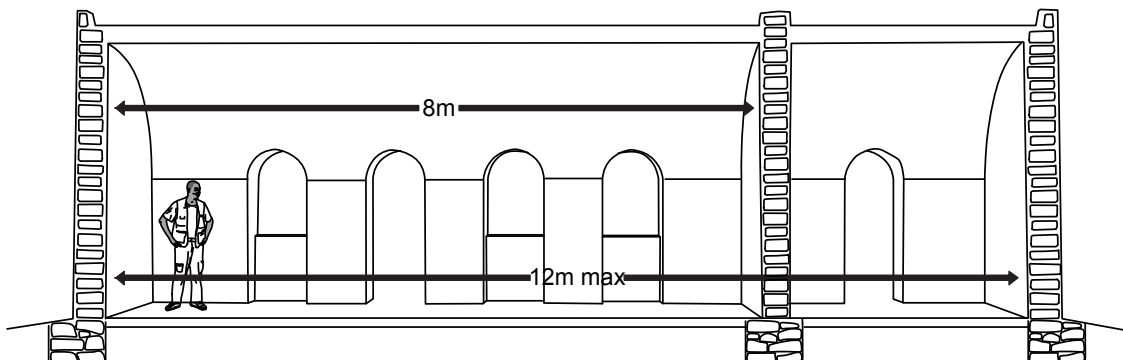

3.4

RULES FOR SITING & SIZING NUBIAN VAULTS HEIGHT OF VAULT BASELINE (HVB)

1

Economical: 120cm

This small format economises on construction materials, but still allows for a comfortable house.
REMINDER:
there is no minimum height.

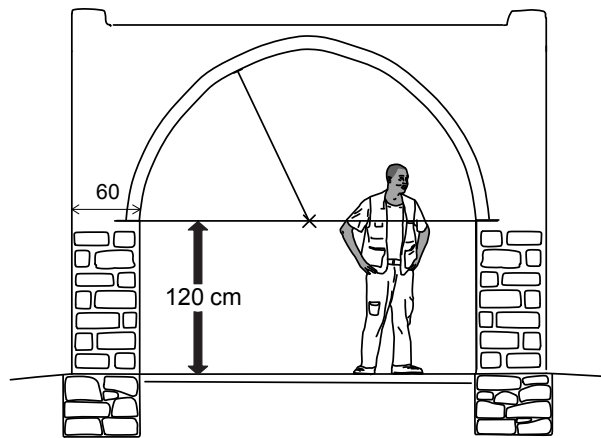

2

Standard: 150cm

A baseline for the vault at 150 cm above ground level gives a good space / cost ratio for the construction of a house

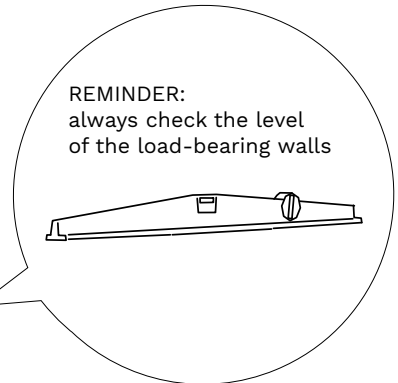
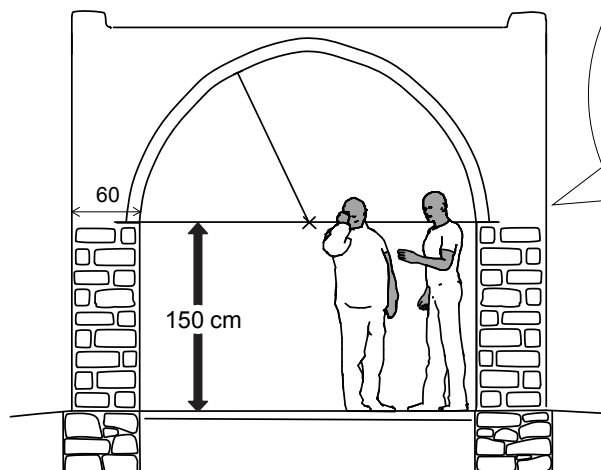

3

Maximum: 175cm

This is the maximum height above floor level for the baseline: the vault will not be stable above this height.

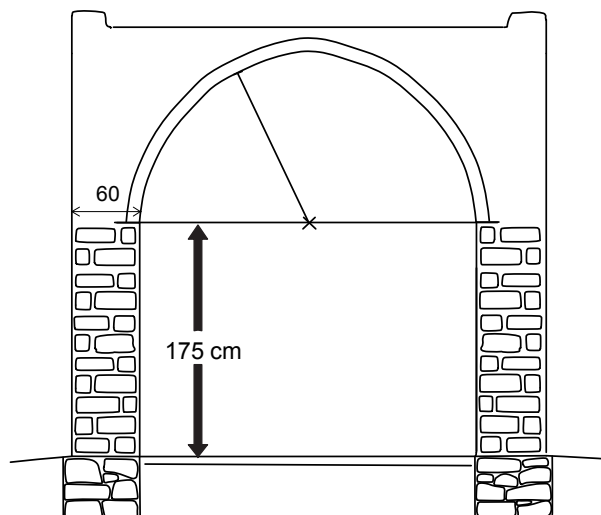

4.1

FOUNDATIONS

FOUNDATIONS OF LOAD-BEARING WALLS, GABLE WALLS, DIVIDING WALLS & PARTITIONS

1
External load-bearing wall

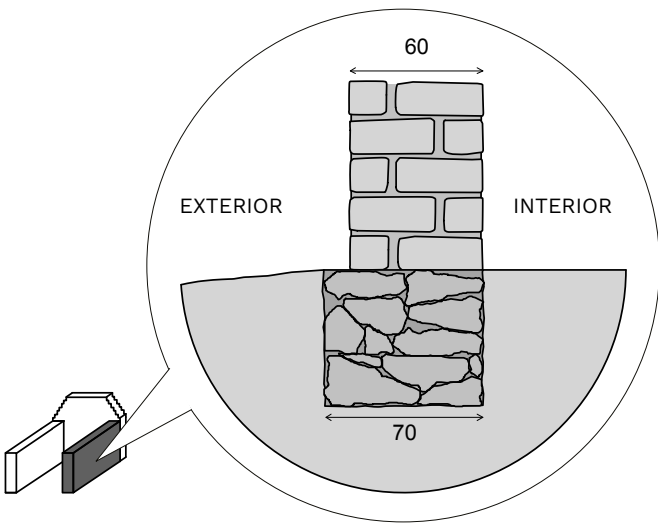

4
Gable wall

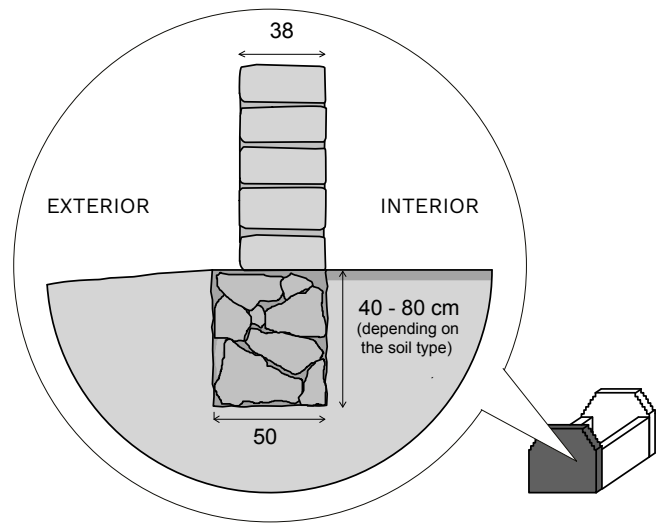

2
Interior load-bearing wall
(between two vaults)

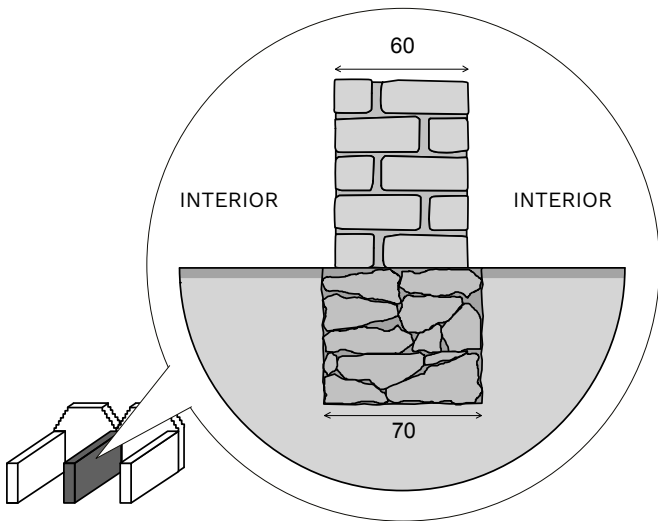

5
Interior dividing wall

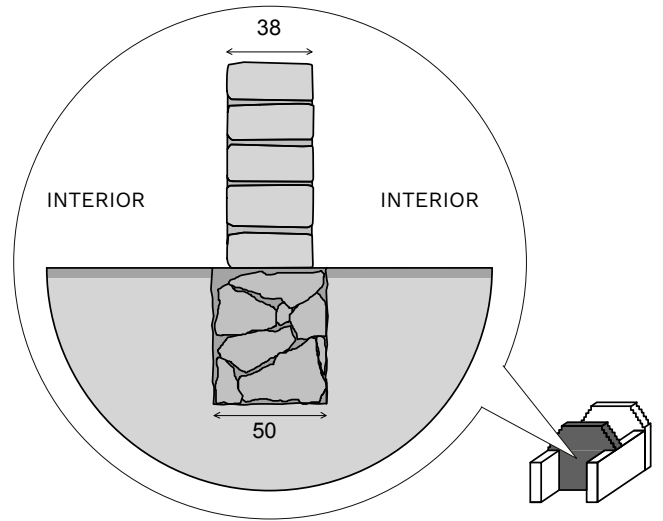

3
Reinforced load-bearing wall
(below a second storey, or where the vault height exceeds 175cm)

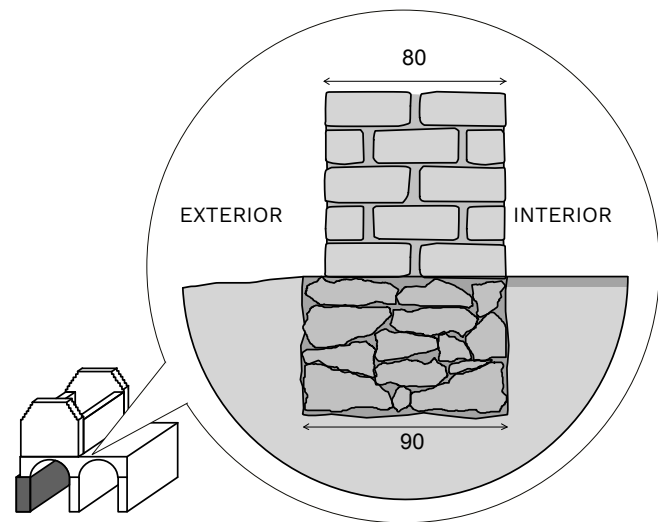

6
Partition wall

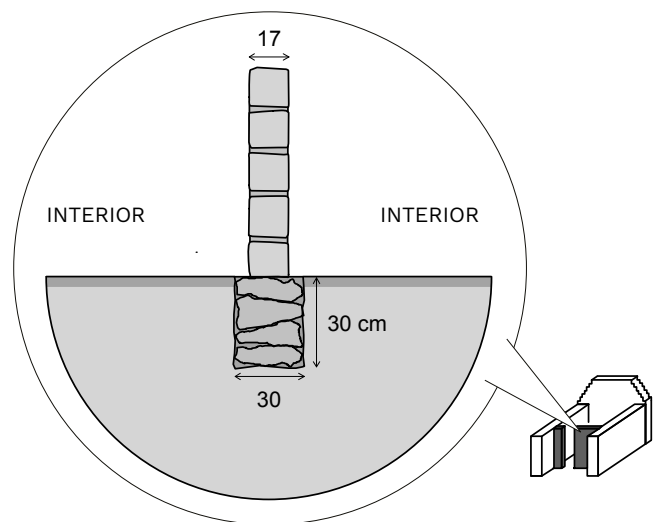

4.2

FOUNDATIONS

MARKING OUT THE SITE

[1] To position the cords which mark out the site, use the 3,4,5 rule, which guarantees right angles at each corner.

[2] Extend the cords and check that $A=A$, $B=B$, and $C=C$. Make sure the stakes are firmly fixed. The cords delineate the exterior of the foundations.

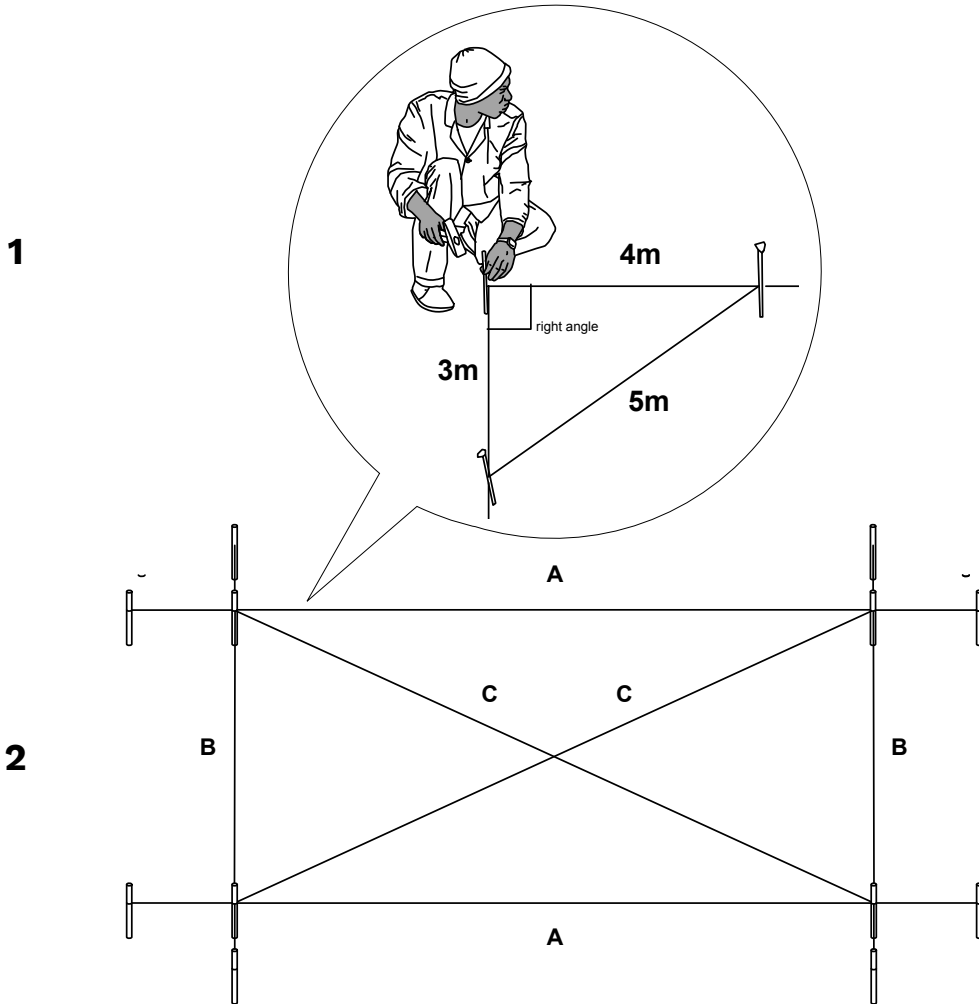

REMINDER: THE LOAD-BEARING WALLS MUST BE PARALLEL TO EACH OTHER!

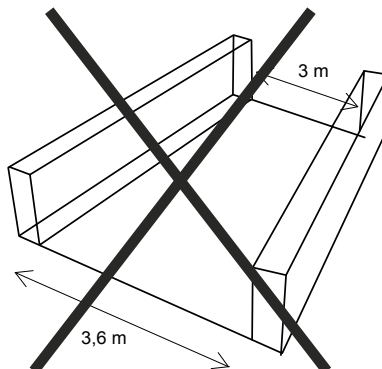
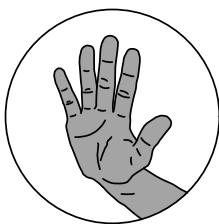

4.3

FOUNDATIONS

EXCAVATING THE TRENCHES

1

Guided by the cords, trace the edges of the foundations with a pickaxe, or with a line of ash.

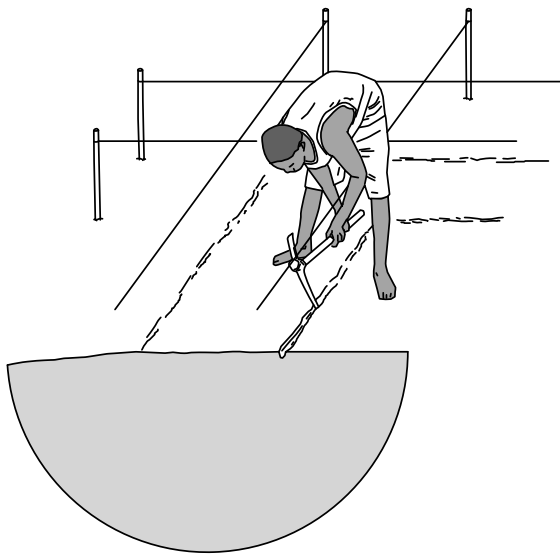

2

Once the edges are accurately marked out, remove the cords and excavate the foundation trenches, making sure the base is well and flat.

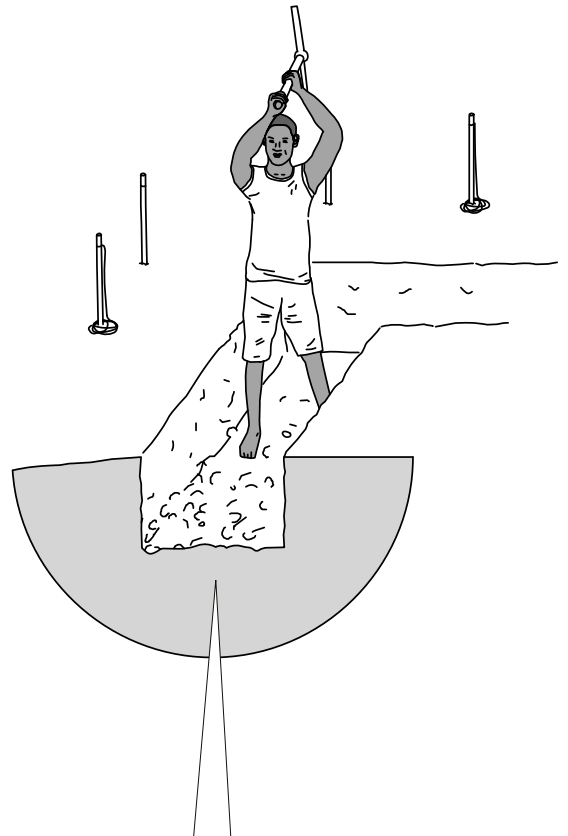

The depth of the trenches depends on how hard the earth is.
NOTE: if, in the same trench, there are both stones and soil, dig out the soil but leave the stones in the trench.

hard earth:
relatively shallow trench

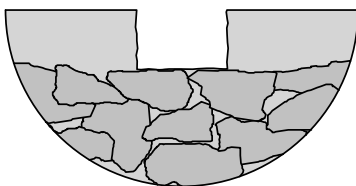

normal earth:
minimum depth of trench of **60cm**

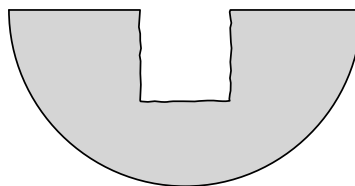

soft earth:
minimum depth of the trench at least as deep as its width

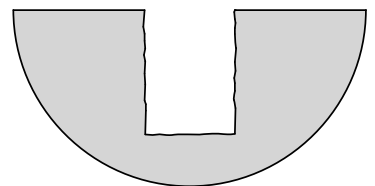

4.4

FOUNDATIONS

FOUNDATIONS IN STONE & EARTH MORTAR (BANCO)

The stones act as blocking masonry, over which the earth mortar is laid, in this type of foundation. To guarantee the stability of the foundations, the rocks and stones must be positioned in the trench with great care.

NOTE: if plumbing is to be installed, gaps must be made across the foundations for later installation of pipework.

1 Rocks

Place big rocks flat on the outer side of the trench.
Fill all gaps with earth mortar (banco) and stones.

2 Backfill

Cover the top layer of rocks and stones,
and gaps between them, with a layer of banco

REMINDER:
The head mason must supervise the
apprentices' work on the foundations

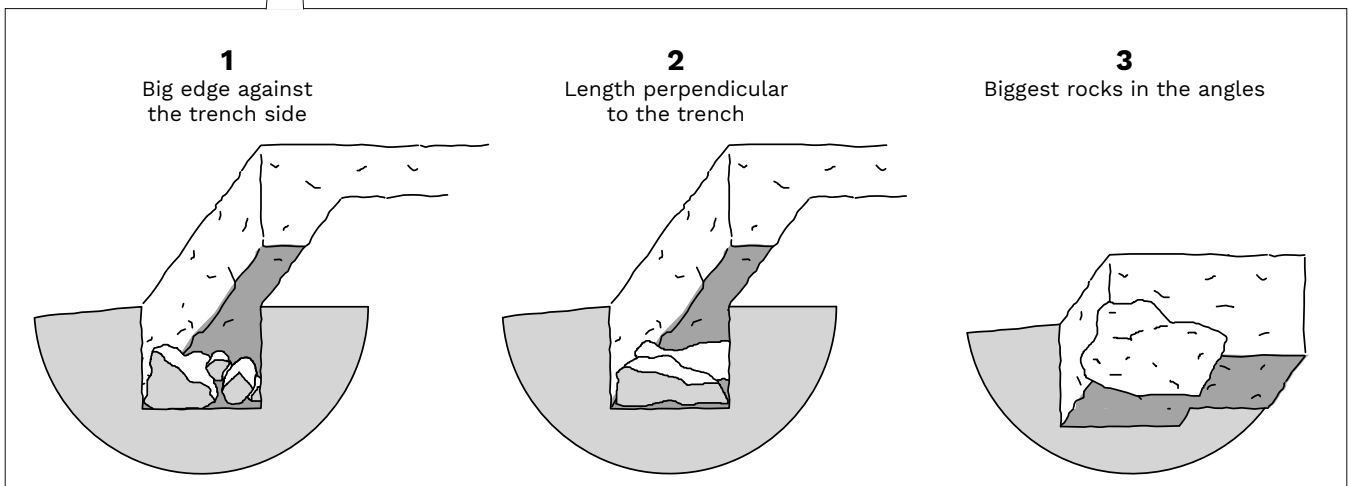
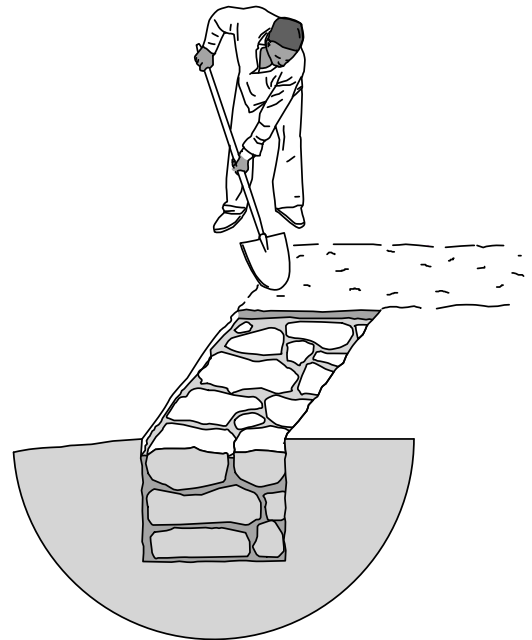
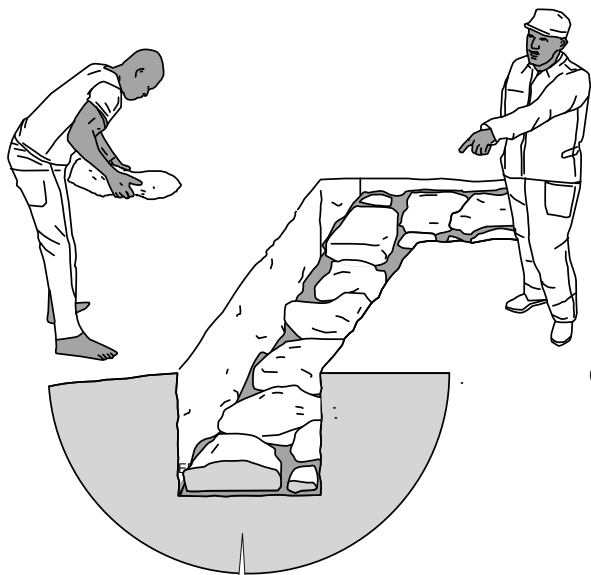

4.5 ★ AD

FOUNDATIONS

RAMMED EARTH FOUNDATIONS

If no rocks are locally available, the foundations can be made with rammed earth, but this requires specialist skills. NV masons must first take care to thoroughly master the use of this technique.

1

The dimensions of the trenches are the same as for rock-based foundations. Where feasible, make sure they are as deep as they are wide!

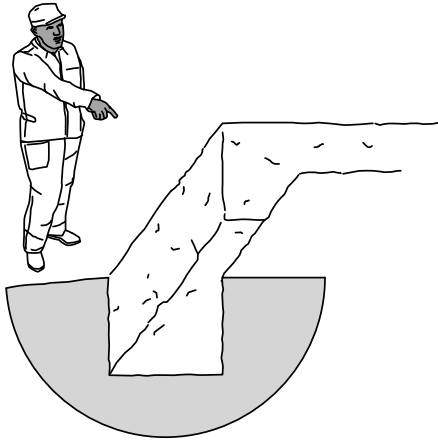

2

Specific equipment: plastic tarpaulin, tampers (manual or pneumatic).

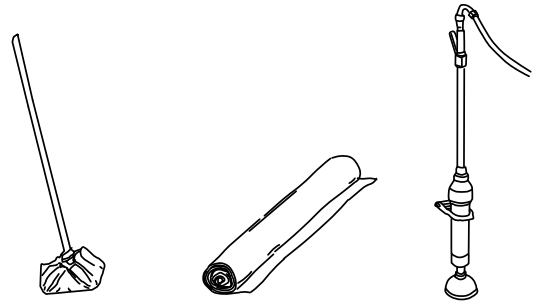

3

Preparation of the earth
Wetting: the earth must be moist but not sticky to the touch. It should include +/- 20% of gravel.

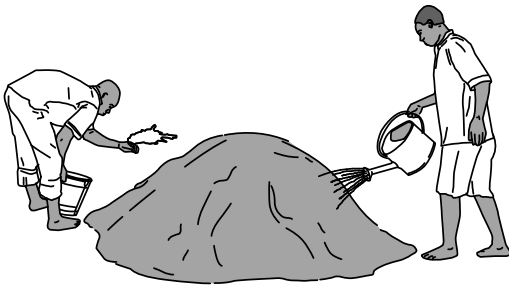

4

Placement of the plastic tarpaulin round the external edge and base of the trench.

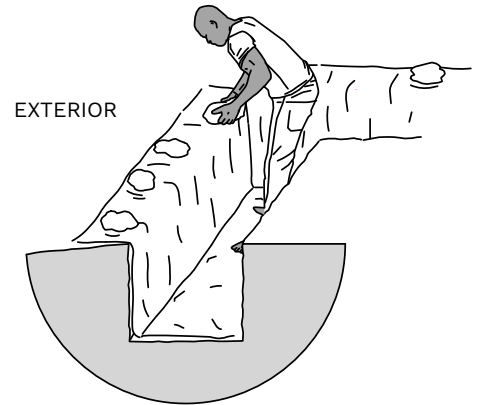

5

Filling of the trench with successive 20cm layers.

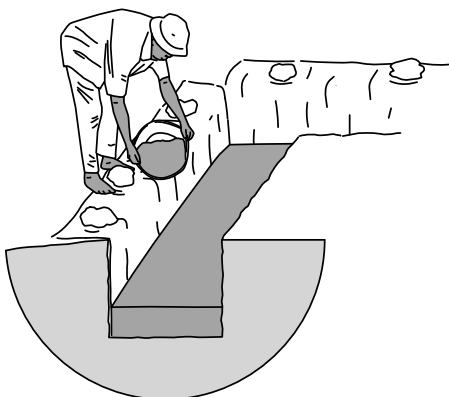

6

Each layer must be strongly tamped and compacted.

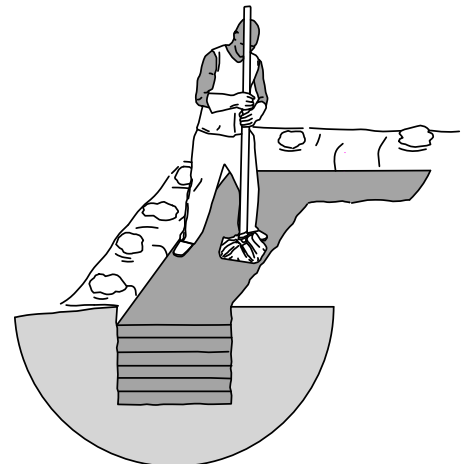

5.1

THE WALLS

WALL THICKNESS

1

Load-bearing wall 60cm:

- if HVB less than 175cm
- if two-storey building, then only for internal walls (between two vaults)

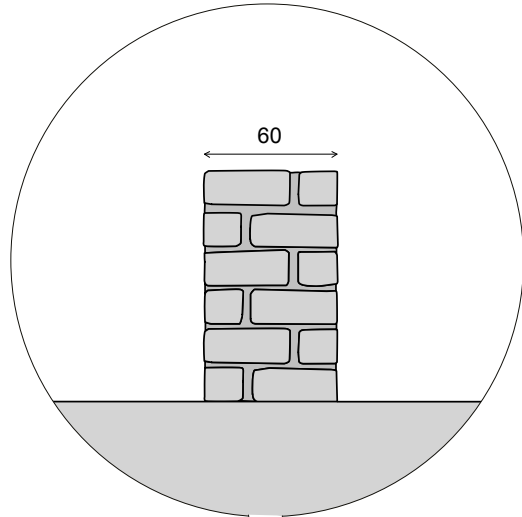

if HVB
less than
175cm

or

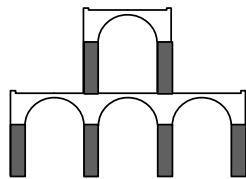

2

Load-bearing wall 80cm:

- if HVB over 175cm
- for external walls of a two-storey building

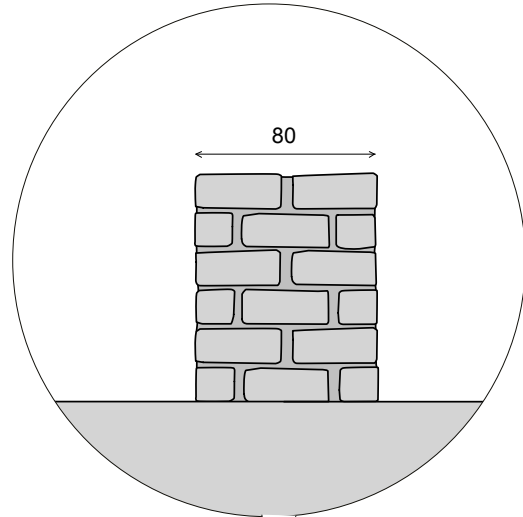

if HVB
over
175cm

or

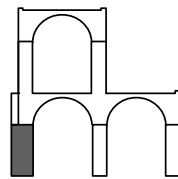

3

Gable & dividing walls
38 cm

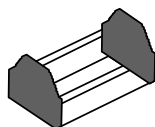
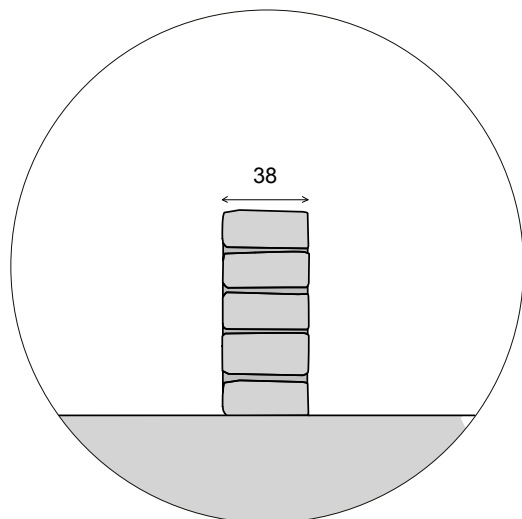

or

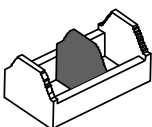

4

Thick partition wall
17 cm

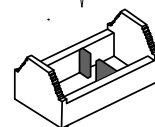
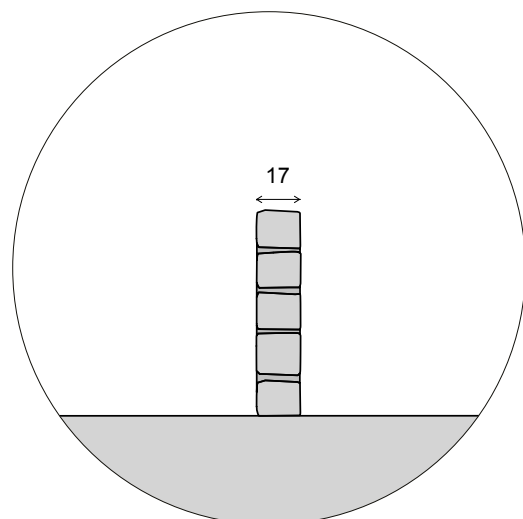

5.2

THE WALLS

CHECKING ALIGNMENT & VERTICALITY

1

Verticality

To ensure the walls are vertical, use a plumb line (or just a weight at the end of a cord). The load-bearing walls, dividing walls, and partitions must be raised absolutely vertical.

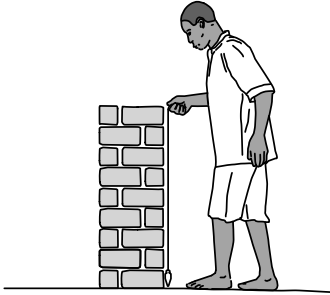

2

The gable walls must be slightly inclined towards the inside of the vault, 1cm for every 150 cm height from the base of the vault.

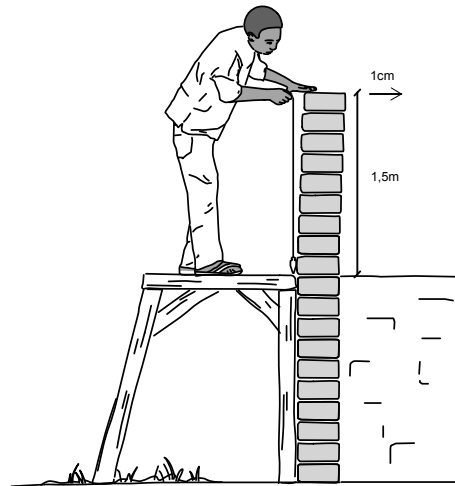
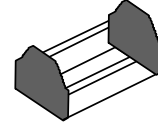

3

Alignment

Course after course, the alignment of the bricks must be checked by stretching a cord between the corner bricks along the row under construction, once the corners have been set vertical.

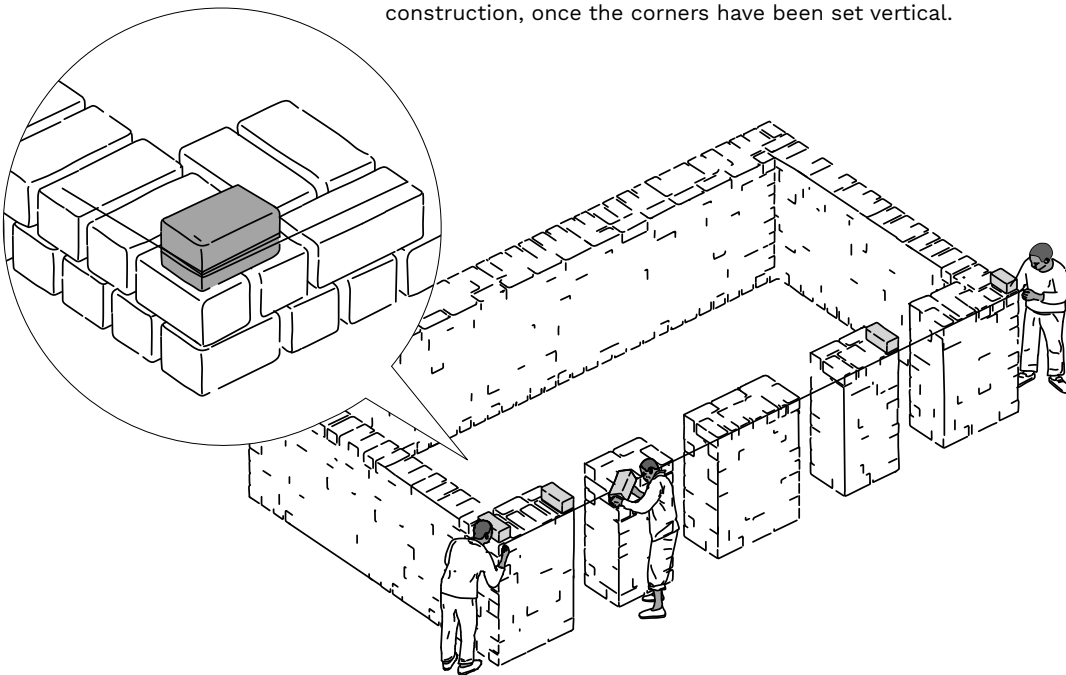

5.3

THE WALLS

BASIC PRINCIPLES OF BOND PATTERNS

1
First course of bricks

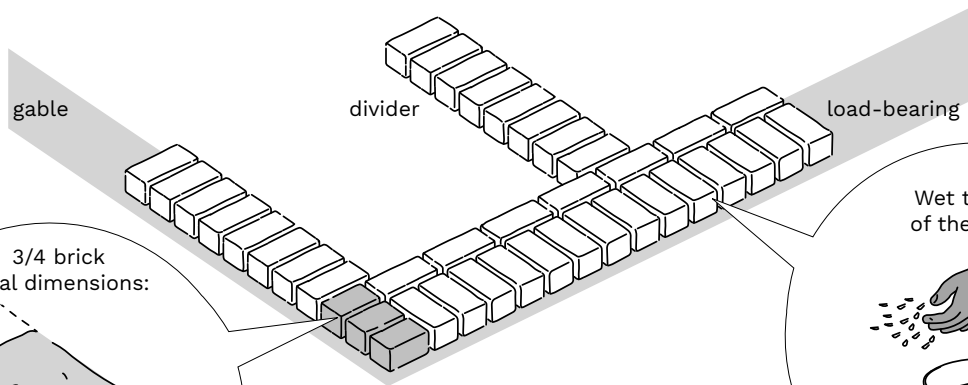

3/4 brick
Ideal dimensions:

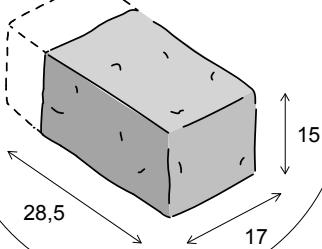

2
Second course, invert the orientation of the bricks. Take care where courses cross over in the corners.

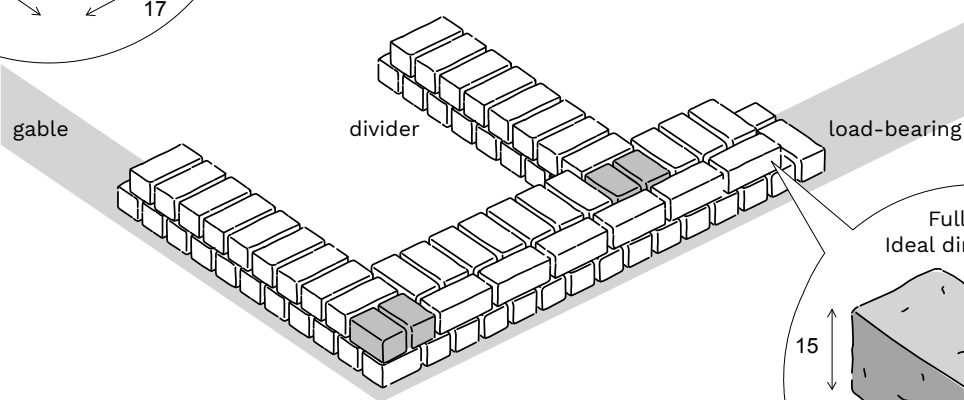

Full brick
Ideal dimensions:

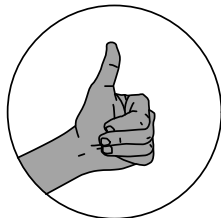
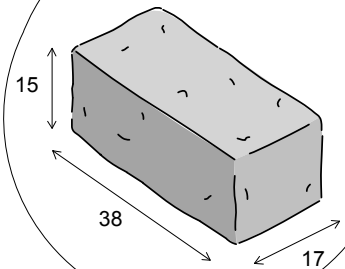

Important:
Offset the joints in each course

Ideal thicknesses:
- vertical joints: 4cm
- horizontal joints: 2cm

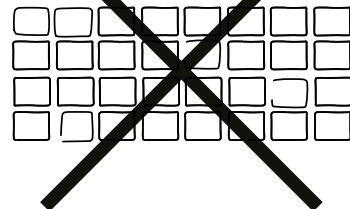
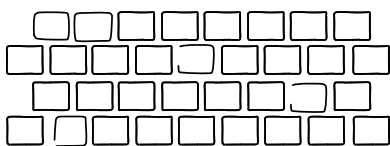
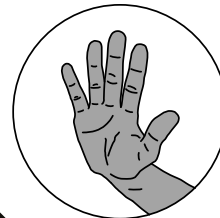

5.4

THE WALLS

BASIC STANDARD BOND PATTERNS

1

Load-bearing wall 60 + gable wall 38

1st COURSE

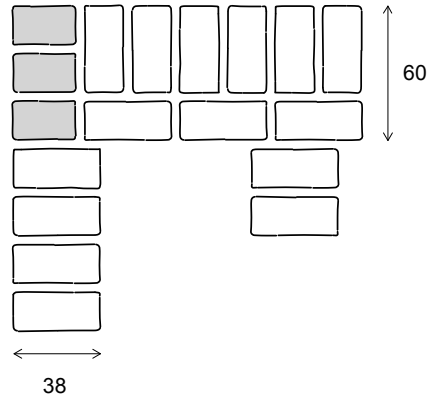

2nd COURSE

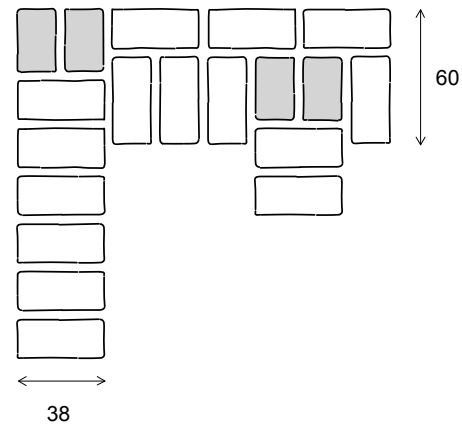

SUPERPOSITION

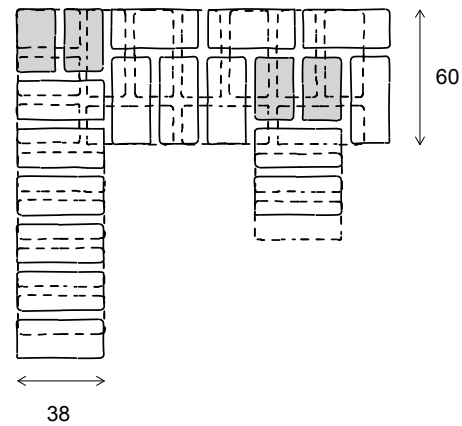

5.5

THE WALLS

VARIANTS OF THE STANDARD BOND PATTERN

Three common variants of the standard pattern are shown below.

1

Load-bearing 60 + gable 60

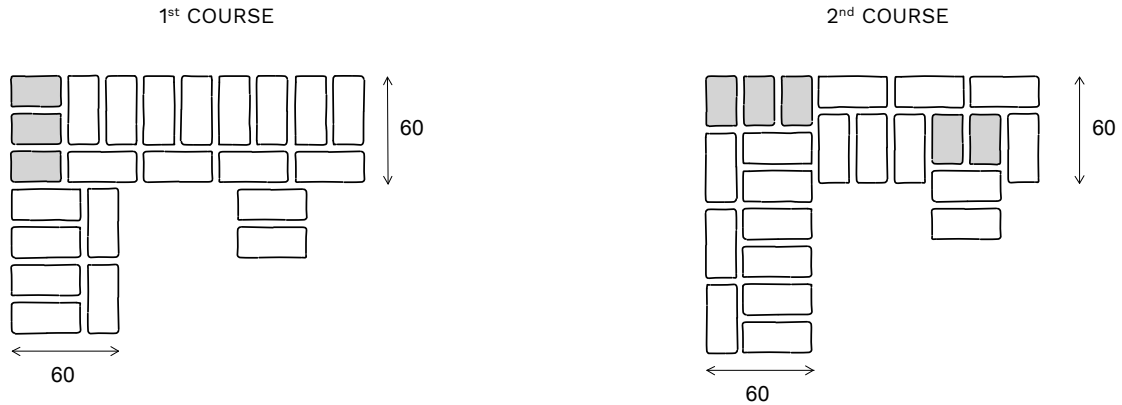

2

Load-bearing 80 (supporting a 2nd storey) + gable 38

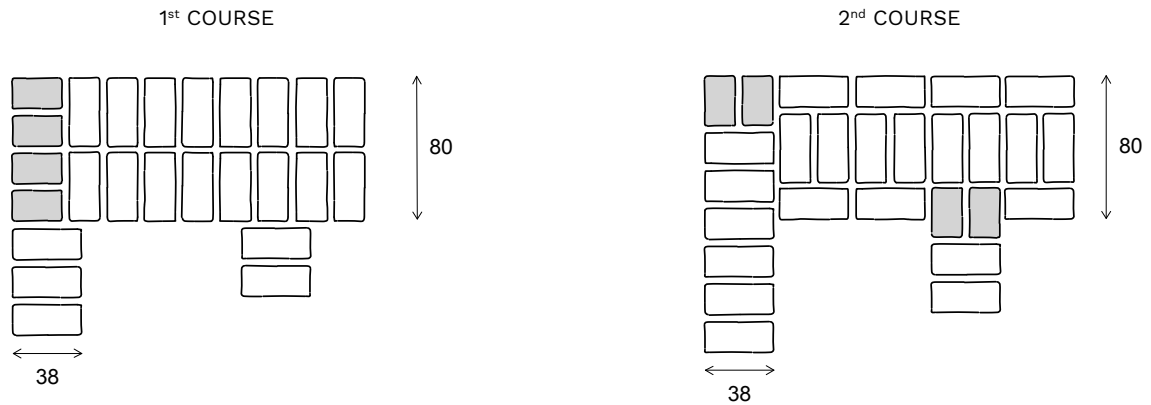

3

Load-bearing 80 (supporting a 2nd storey) + gable 80 (reinforced gable wall)

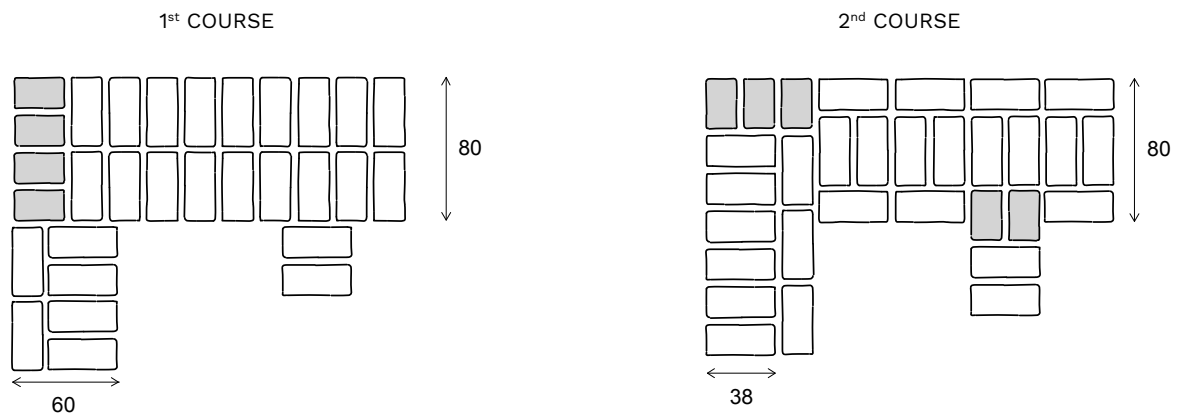

5.6 ★ AD

THE WALLS

BOND PATTERNS FOR MIXED BRICK WALLS

To allow for a protective cement render on the external surface (with stony mud bricks), or if using stone blocks, 'mixed' walls can be built, using standard mud bricks only for the interior wall surface.

The stony bricks or the stone blocks must have the same dimensions as the inner mud bricks, and be built using earth mortar. Once built, the stony bricks will receive a cement render, and the joints of the stone blocks pointed with cement.

REMEMBER: soak the stone blocks in water before placing them, so that they don't suck all the moisture out of the mortar.

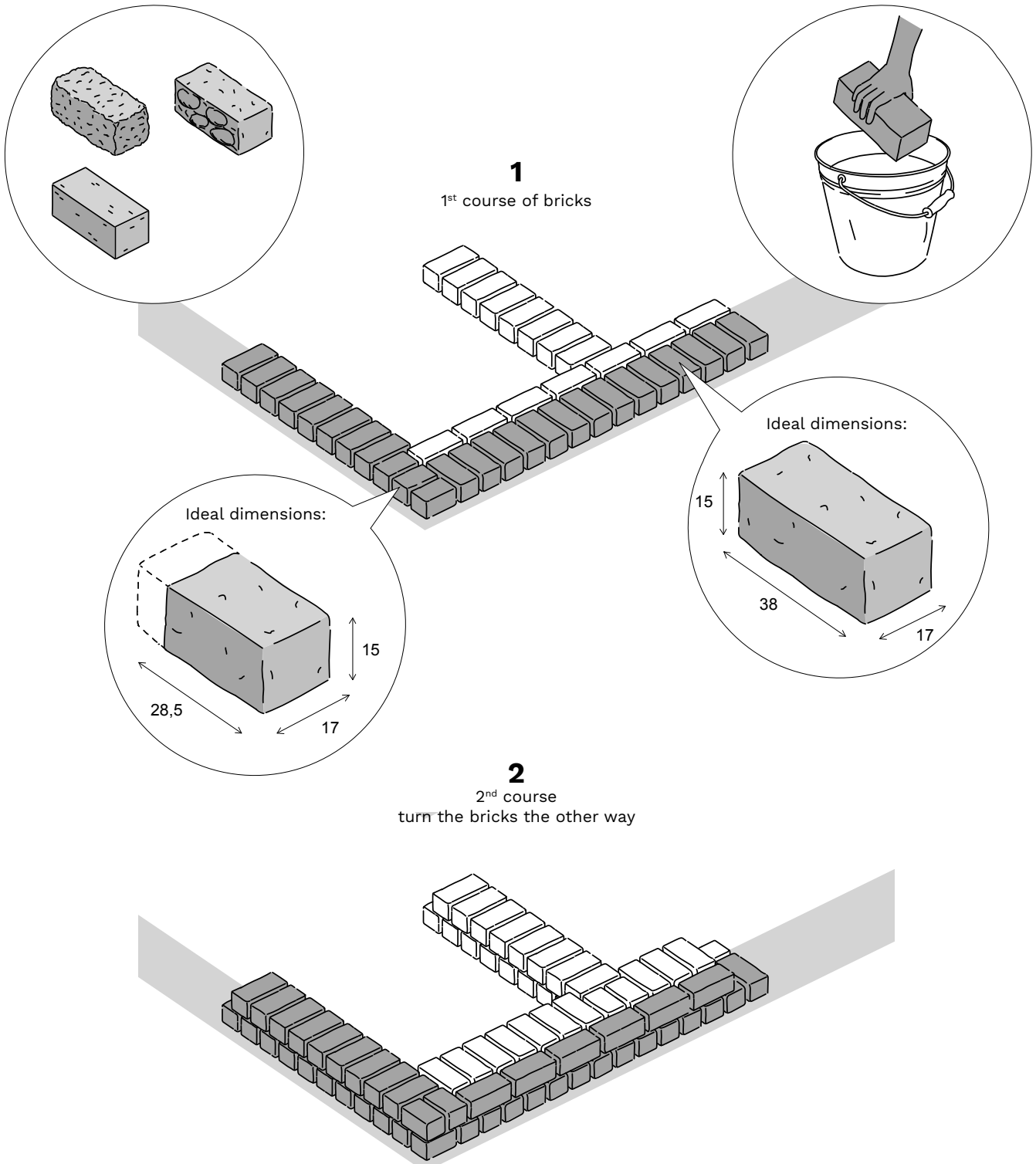

5.7 ★ AD

THE WALLS

PRODUCTION & BONDING OF STONY BRICKS

The stones must be about the size of an orange, around 10cm diameter. For stretcher bricks (long side), the stones should be placed in the bottom of the mould before pouring in the mud (banco). For header bricks (brick end) the stones should be put in the mould at the same time as the banco. Otherwise, the procedure is the same as for ordinary mud bricks.

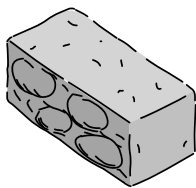
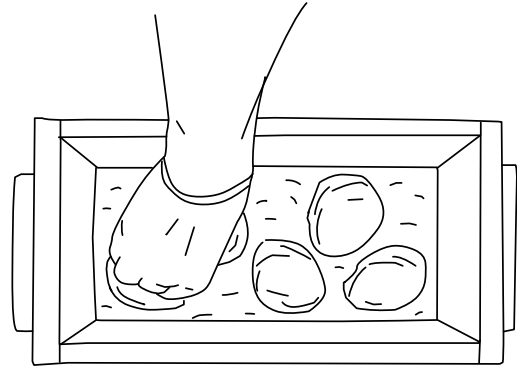
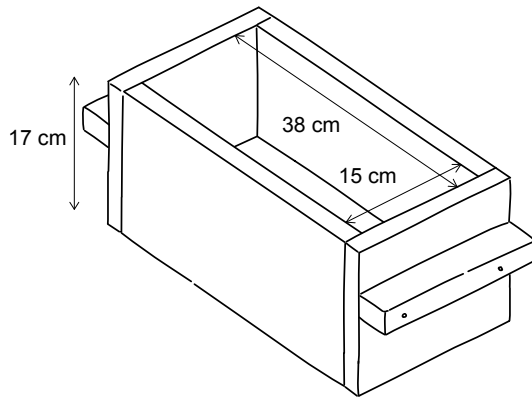

Stretcher

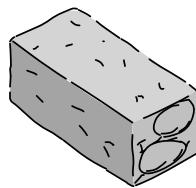

Header

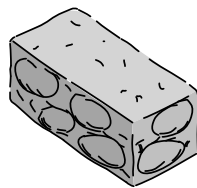

Corner
brick

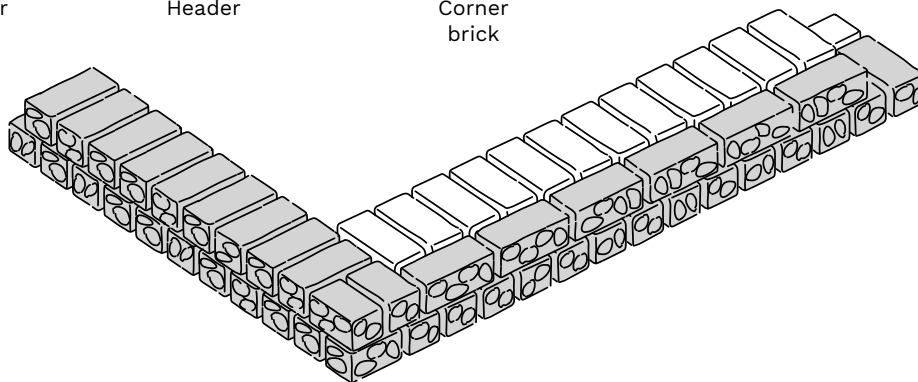

1

Arch made with small bricks. Insert small stones (pebbles) in the joints whilst the mortar is still wet.

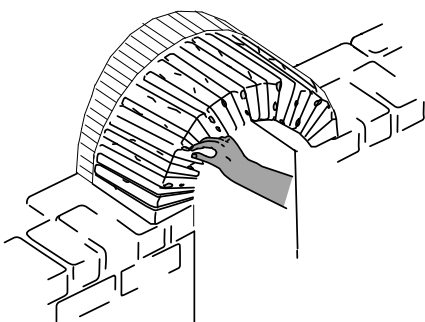

2

Arch made with stony bricks.

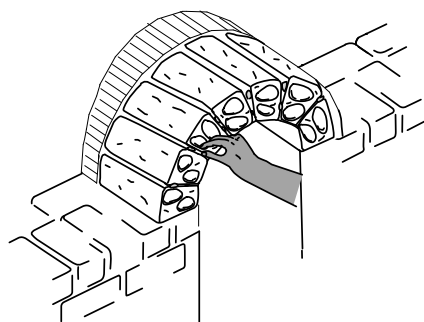

3

When construction is finished, use a pick and wire brush to reveal the stones and obtain a clean surface.

BE CAREFUL:
take care not to loosen the stones!

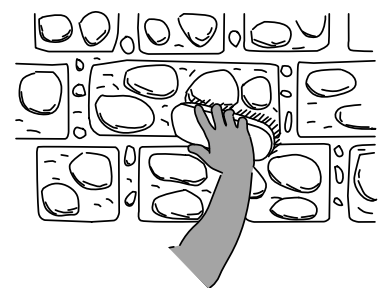

5.8 ★ AD

THE WALLS

REINFORCED WALL BASE

The bases of walls are particularly vulnerable, especially to rain. If a client has sufficient funds, it is always a good idea to reinforce the first few courses of bricks. Various materials can be used, such as cut laterite blocks, or stone or concrete blocks.

REMINDER: the wall bases should always get some extra protection, even if not reinforced.

1

Simple

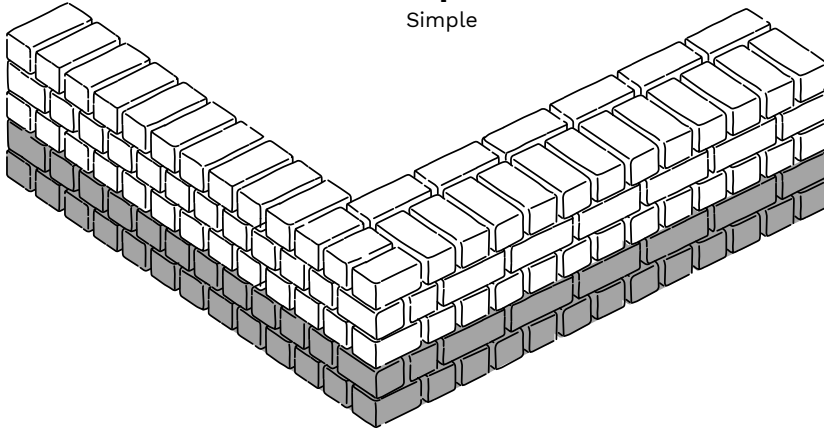

2

With an extra layer of blocks

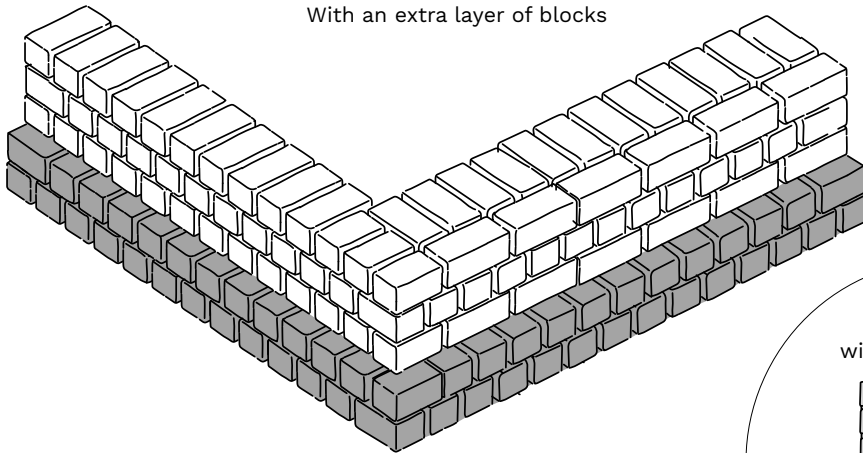

3

With a brick bench

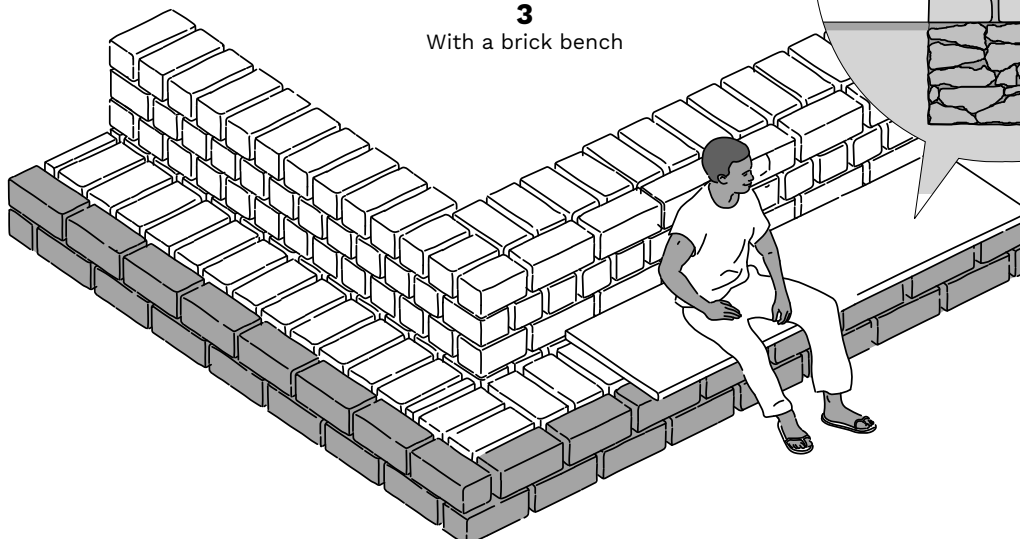

Option:
can be covered
with a concrete slab

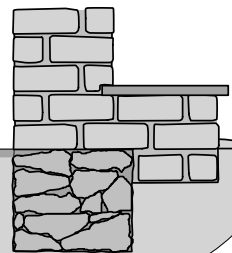

5.9 ★ AD

THE WALLS

CONCRETE REINFORCED WALL BASE

PHASE 2

5.10

THE WALLS

VENTILATION OF THE GABLE WALLS

By using a special bond pattern, it is possible to make openings in the walls for ventilation - see the examples below.

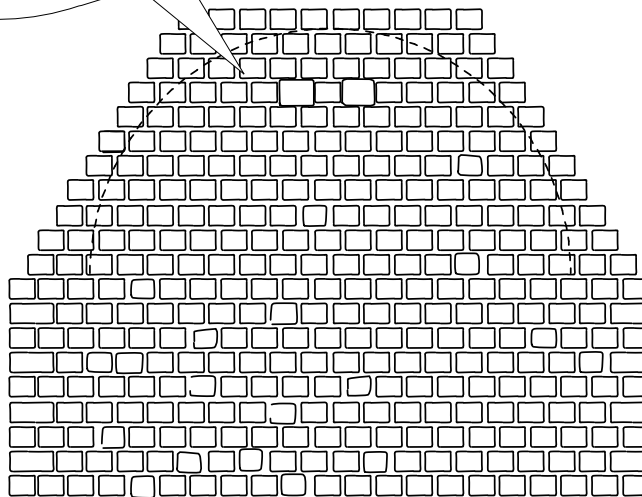
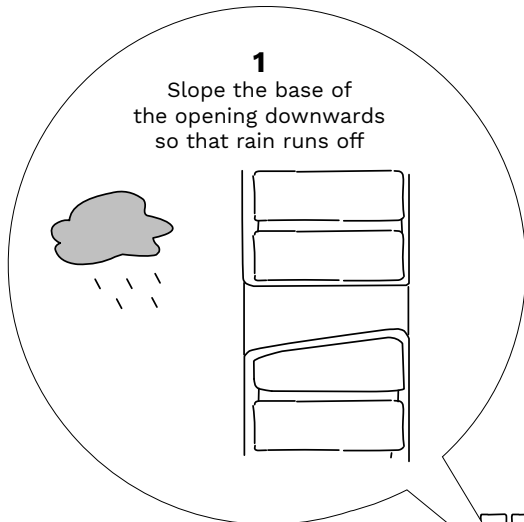

2
Other patterns are possible

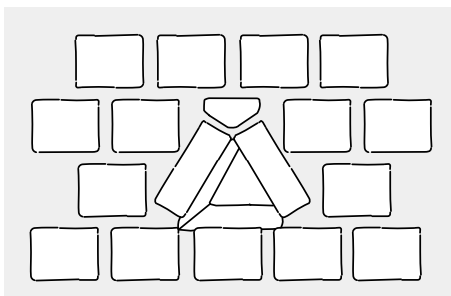

3
Openings can be made using sections of fired clay pipes

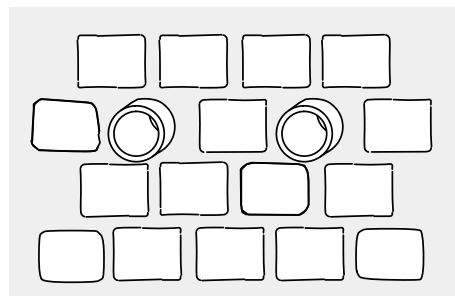

6.1

OPENINGS

RULES FOR WALL OPENINGS

Openings can be made in walls for doors, windows, alcoves etc., as long as certain rules are respected.

Four important rules for load-bearing walls:

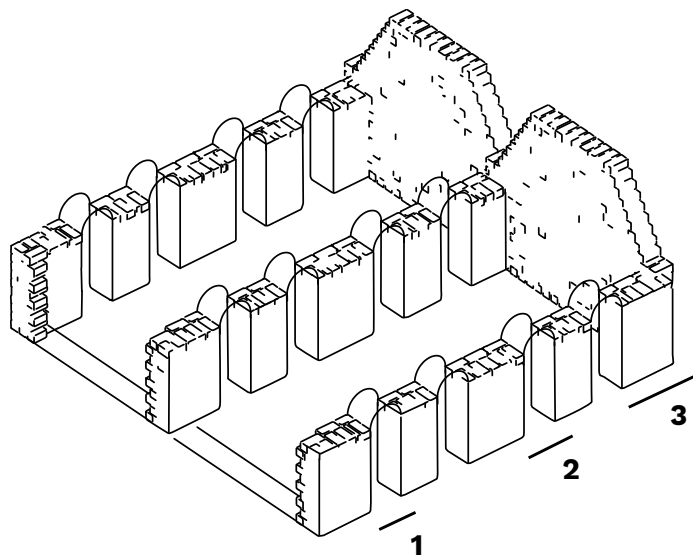

1

Maximum opening width: 90 cm.

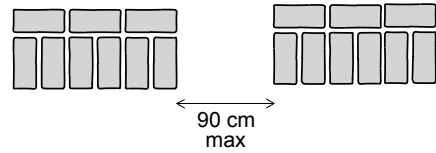

2

Minimum wall length between two openings = width of opening + 20 cm.

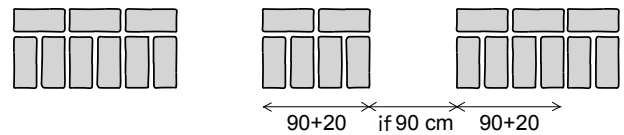

3

At least 100 cm between a corner angle and an opening.

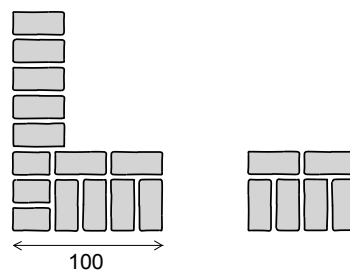

6.2

OPENINGS

RULES FOR WALL OPENINGS

4A
External wall
 recommended ratio of
 1/3 openings to 2/3 full wall

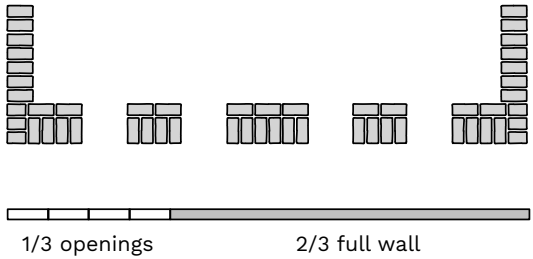

4B
Internal wall
 recommended ratio
 of 2/5 openings to 3/5 full wall

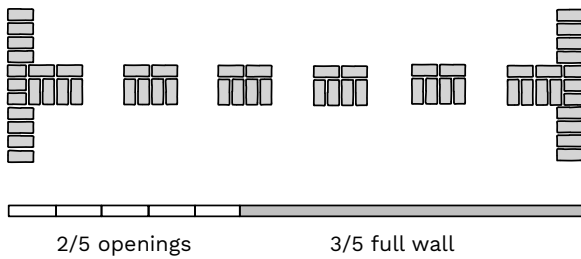

Gable walls: standard openings (up to 100 cm width)
 - minimum return: 40 cm
 - minimum width between two openings: 40 cm

Gable walls can have various types of openings, depending on the client's requirements.
 > 6.5 'Rules for making archways in gable walls' for information on the potential risks of big archways and the rules for their construction.

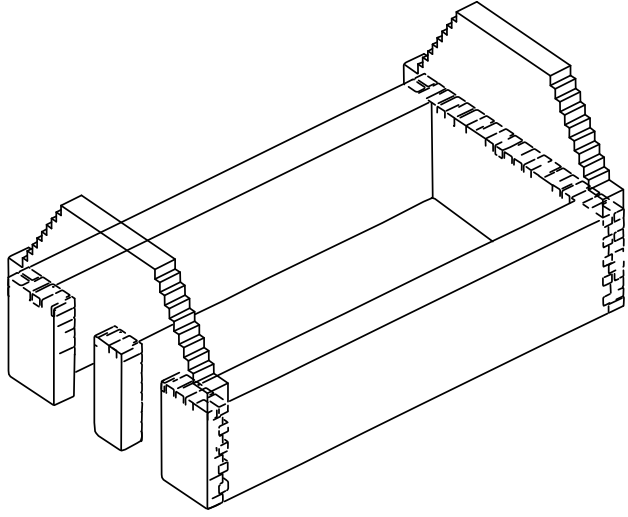
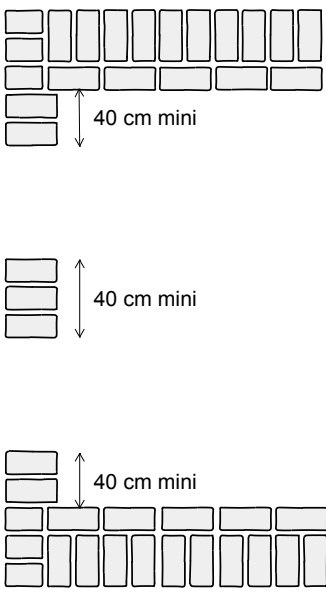

6.3

OPENINGS

BOND PATTERNS FOR DOORS & WINDOWS

Whilst building the walls, it is necessary to allow for construction of doors, windows and alcoves, following the rules in 6.1 and 6.2. Include a partition of 20 cm thick for alcoves.

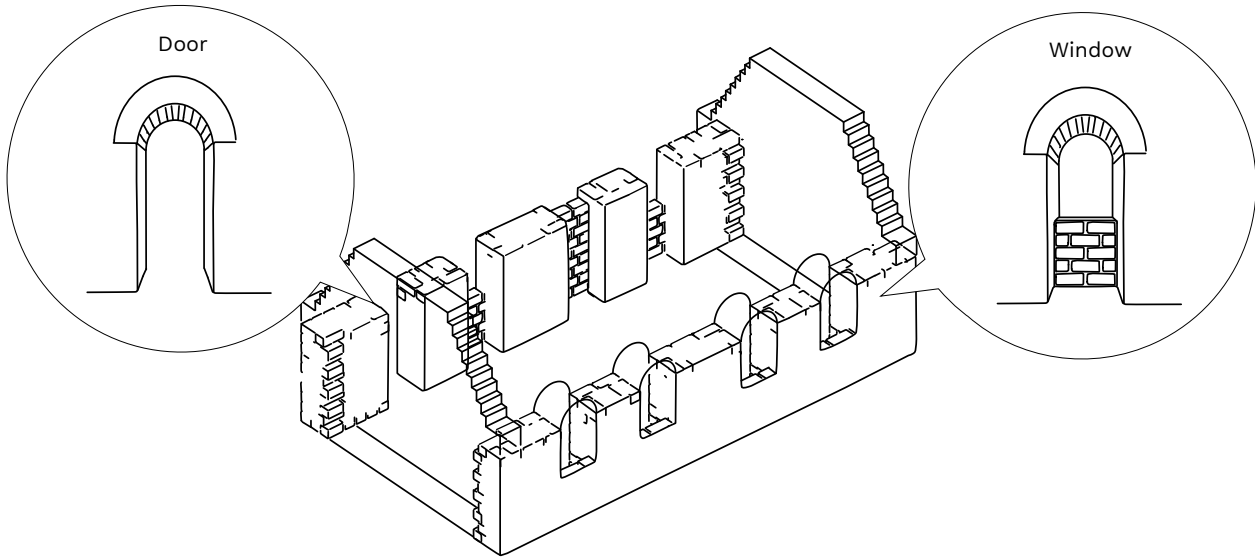

1
1st course of bricks

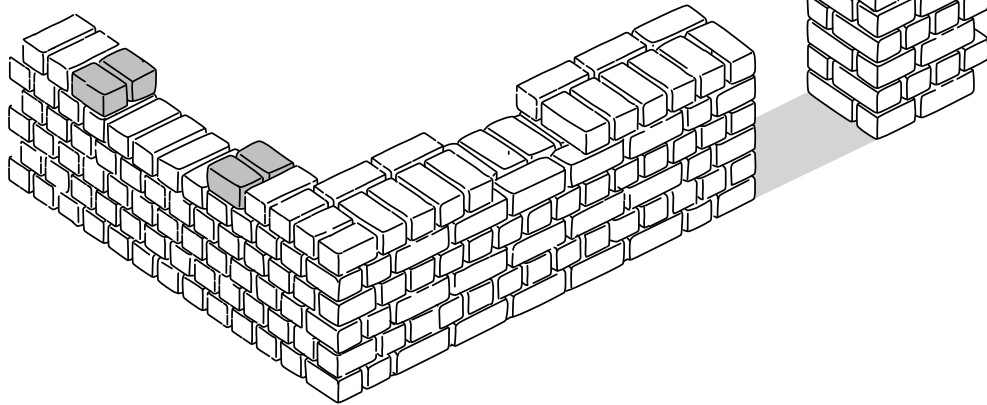

2
2nd course, reversing the orientation of the bricks

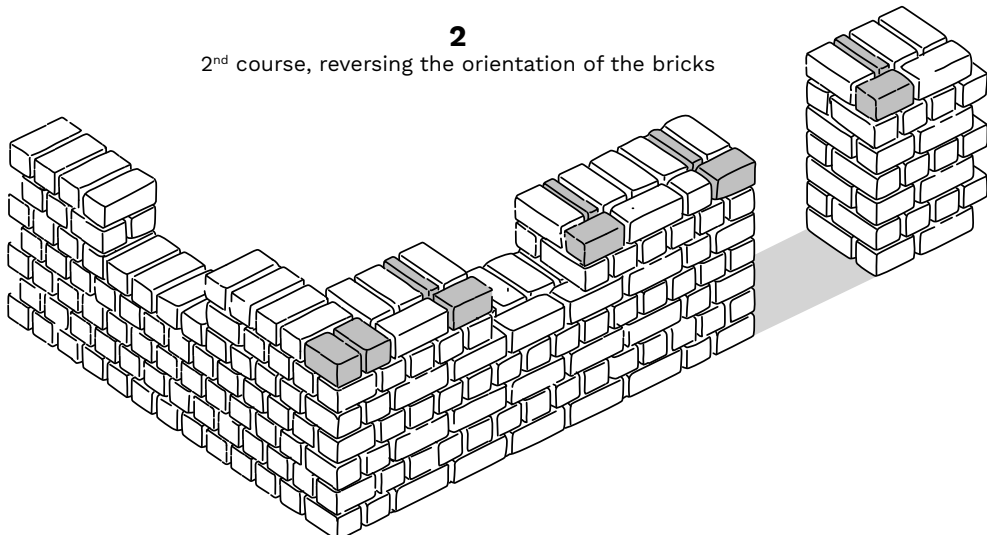

6.4

OPENINGS

BOND PATTERNS FOR ALCOVES

A 20cm partition walling is used to close off the alcove.

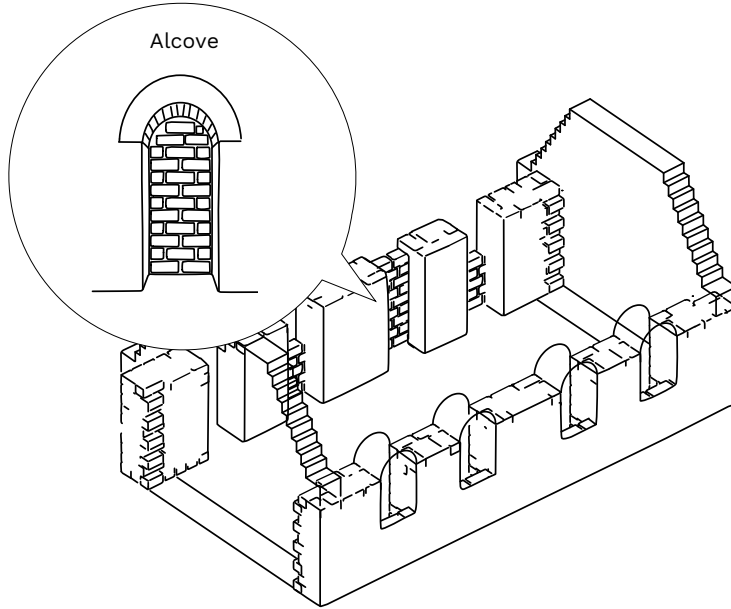

1

1st course of bricks

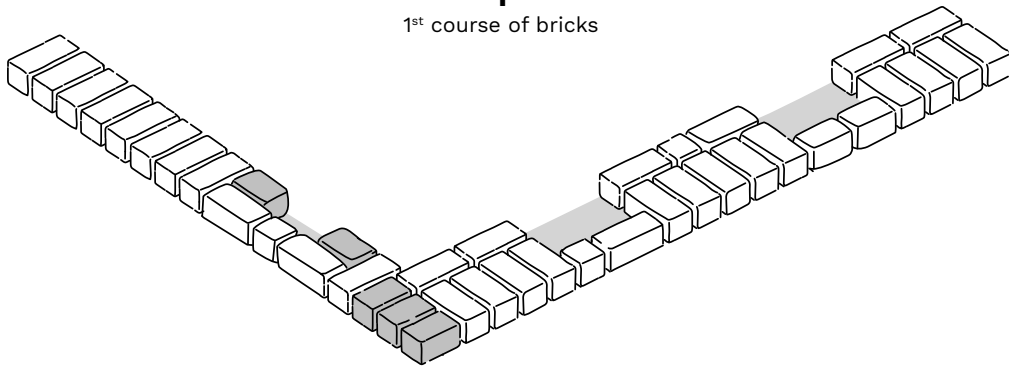

2

2nd course, reversing the orientation of the bricks

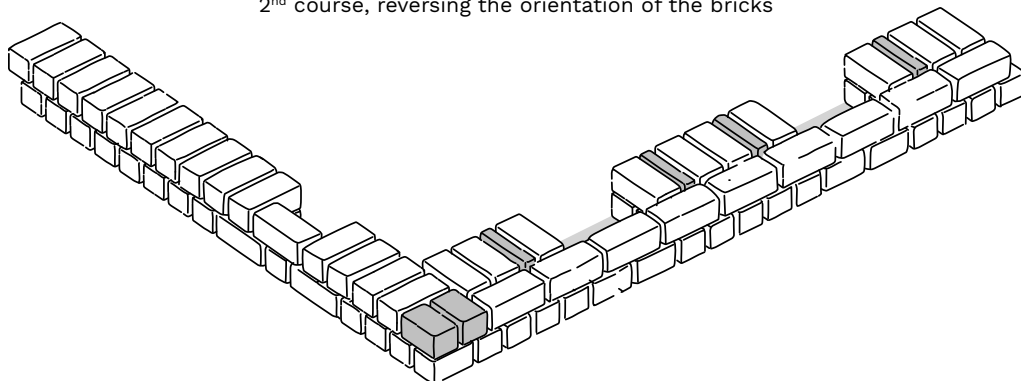

6.5 ★ AD

OPENINGS

RULES FOR MAKING ARCHWAYS IN GABLE WALLS

REMINDER:
In a single-vault building, an archway must never be made the full width of the gable wall! The combined thrusts of the vault and the arch will cause cracks in the structure if the archway is too wide.

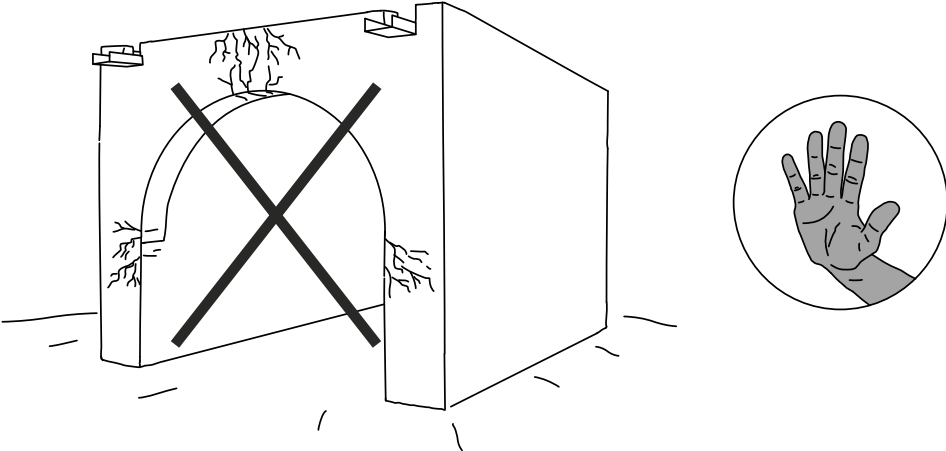

The diagram shows a cross-section of a gable wall with a wide archway. A large 'X' is drawn over the arch, and cracks are shown in the masonry above and on either side of the arch. To the right, a circular inset shows a hand with fingers spread, indicating a warning or prohibition.

- 1**
Wide openings (110 - 120 cm)
- maximum width 220cm
- return 55cm minimum

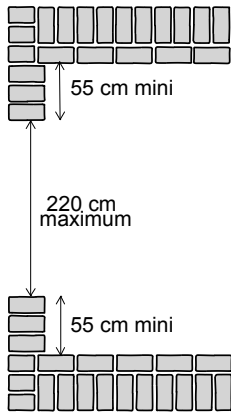

- 2**
Make buttresses in line with the gable wall of the archway.
Here are two examples:

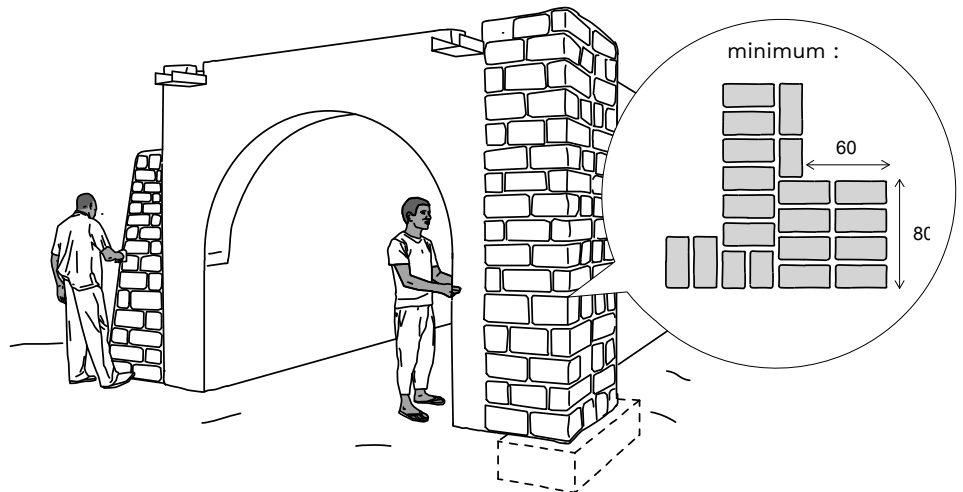

- 3**
Build vaults either side of the one with the archway

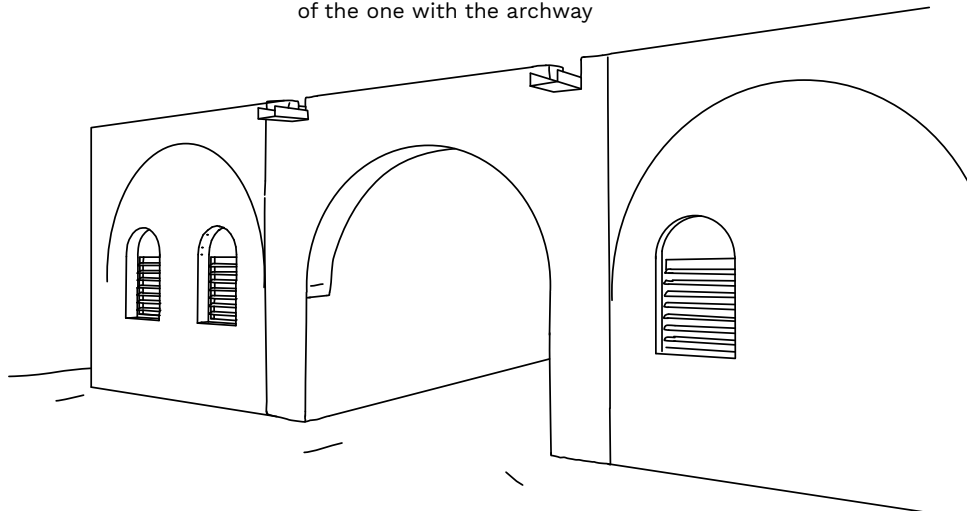

6.6 - A ★ AD

OPENINGS

CONSTRUCTION OF ARCHWAYS IN GABLE WALLS

1

Installation of the form-work.
Adjusting the level of the plank.
Check very carefully the stability of
the base of the form-work.

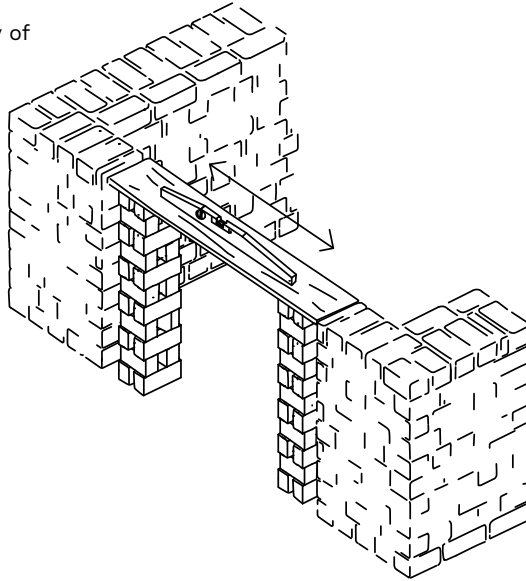

2

Adjusting the alignment and
verticality of the form-work.
Other types of form-work are
possible.

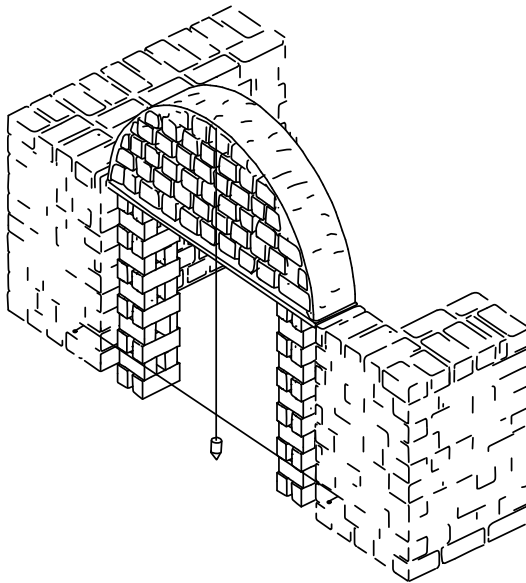

3

Use a compass cable to trace the arc.
Smooth with earth mortar to have a perfect arc.
Cover with a strip of plastic sheeting.

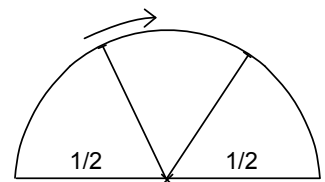
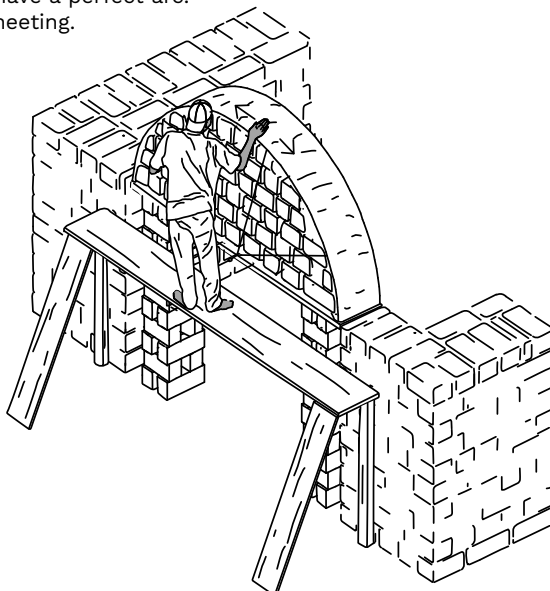

6.6 - B ★ AD

OPENINGS

CONSTRUCTION OF ARCHWAYS IN GABLE WALLS

4

Use the compass cable to to check the correct orientation of the bricks, and, preferably, use the big banco bricks.

Each brick should be placed at a slight angle in the axis of the cable. Insert stones in the mortar-filled joints between each brick.

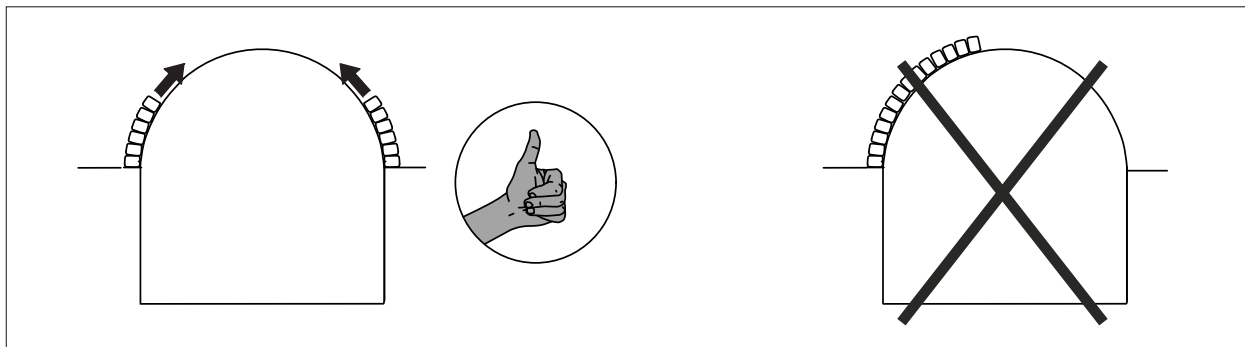
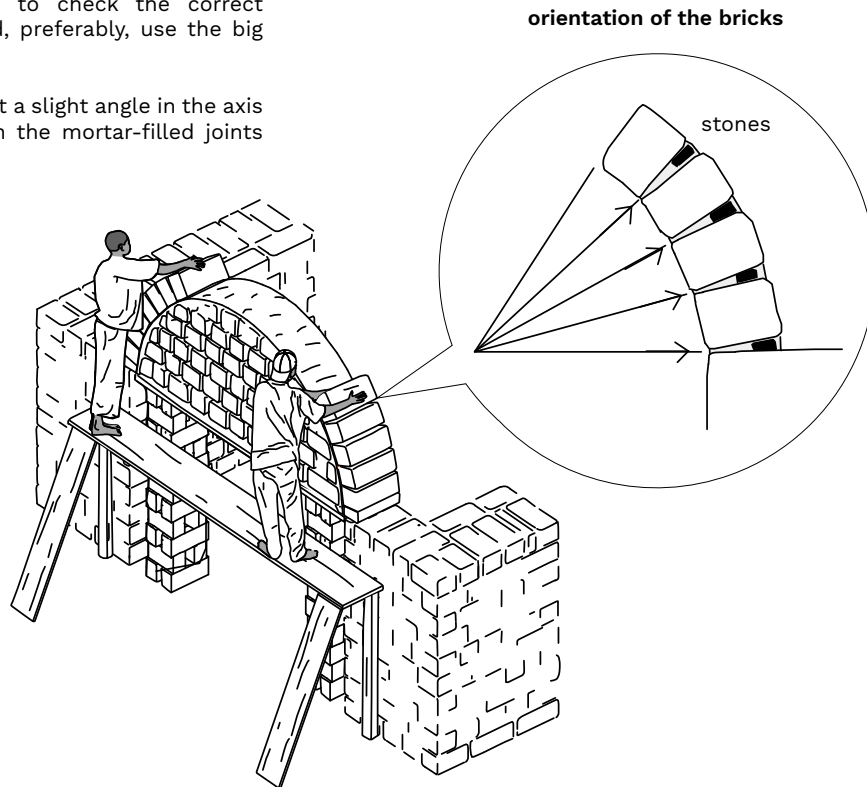

5

Check the vertical alignment of the bricks using a weighted cord against a horizontal cord stretched across the base of the archway.

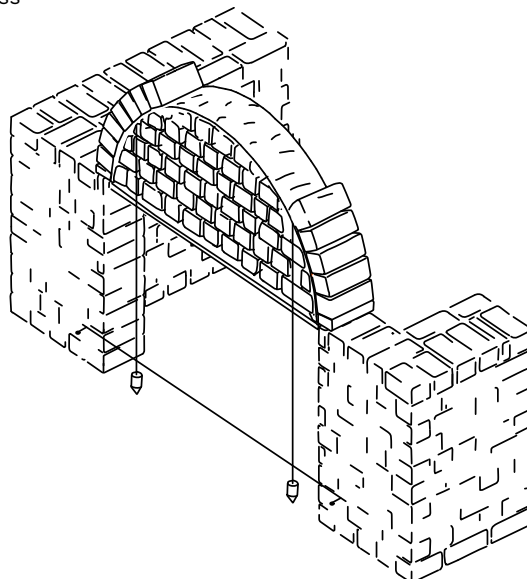

6.6 - C ★ AD

OPENINGS

CONSTRUCTION OF ARCHWAYS IN GABLE WALLS

6

Load the arch at least 3/4 of the way before starting to remove the form-work.

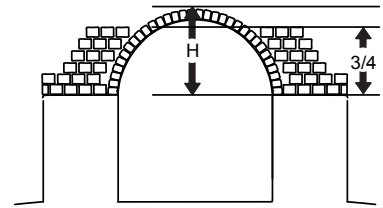
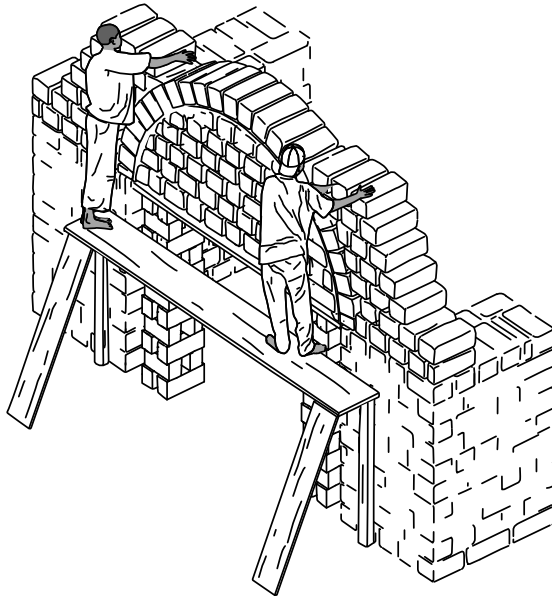

7

Remove the form-work bricks with great care, without putting any sideways pressure on the arch.

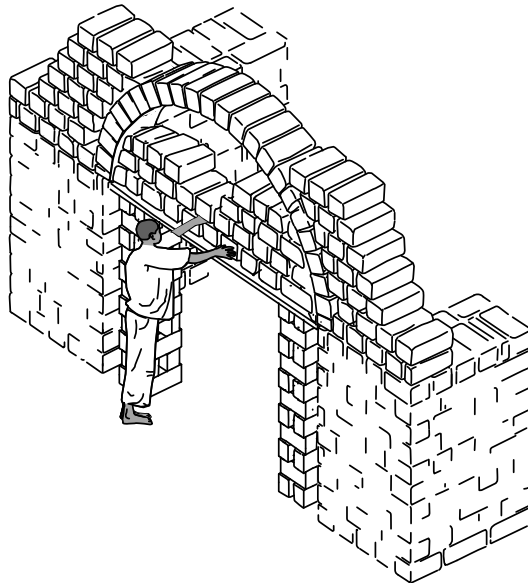

8

The gable wall is then completed after removal of all the form-work.

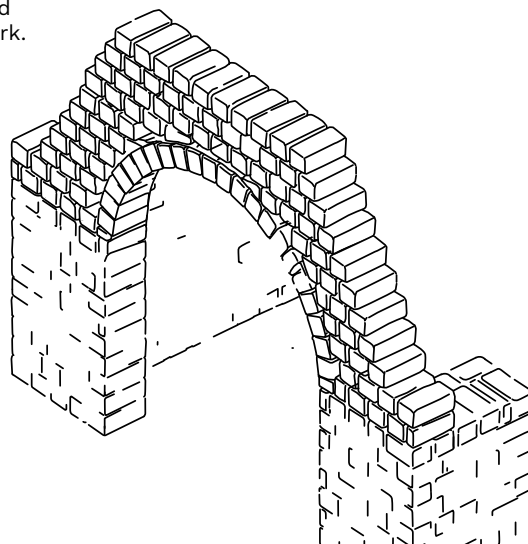

6.7 ★ AD

OPENINGS

CONCRETE BLOCK ARCADES IN LOAD-BEARING WALLS

PHASE 2

6.8 ★ AD

OPENINGS

REINFORCED CONCRETE POST & BEAM DOORWAYS IN LOAD-BEARING WALLS

PHASE 2

7.1

THE COMPASS CABLE

THE COMPASS CABLE - FABRICATION

1

To make the cable, twist together 6 strands of steel wire using a stick.

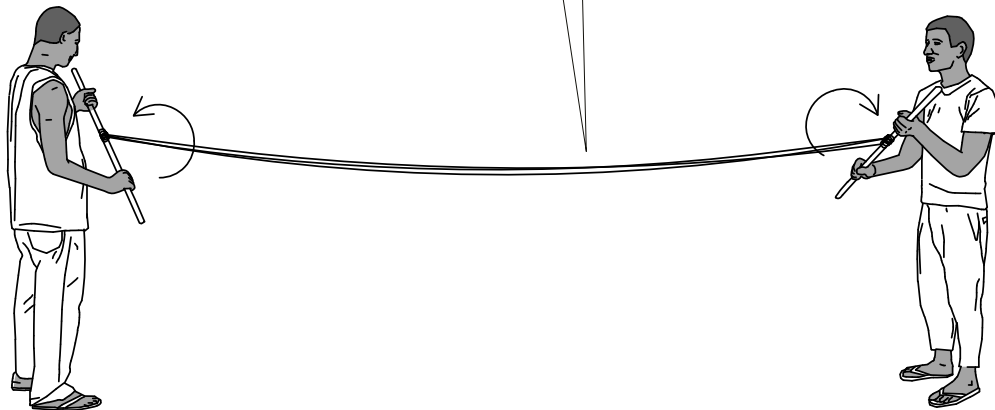
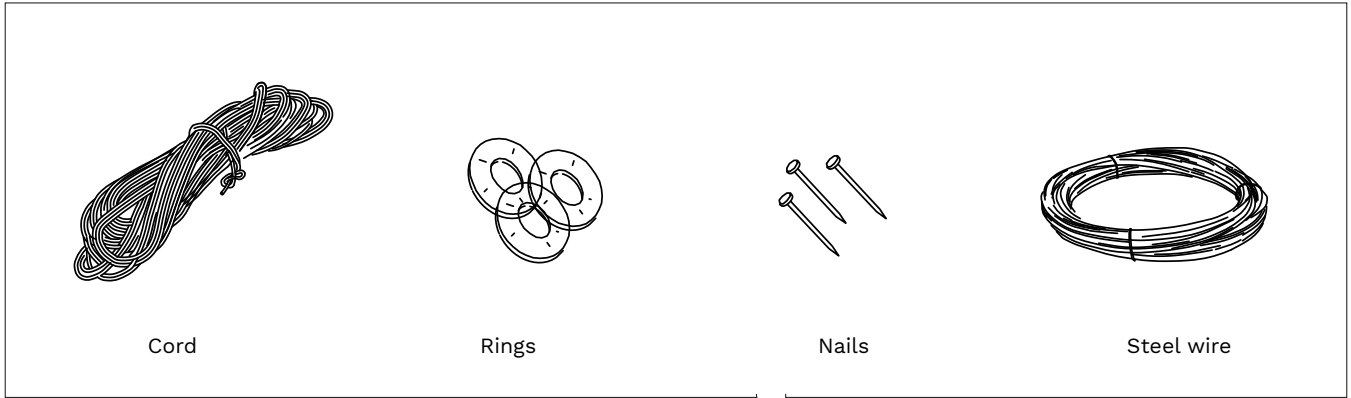

2

Thread 3 rings onto the cable before installing it.
The cord for each ring: 165cm maximum length, with a nail tied to the end.

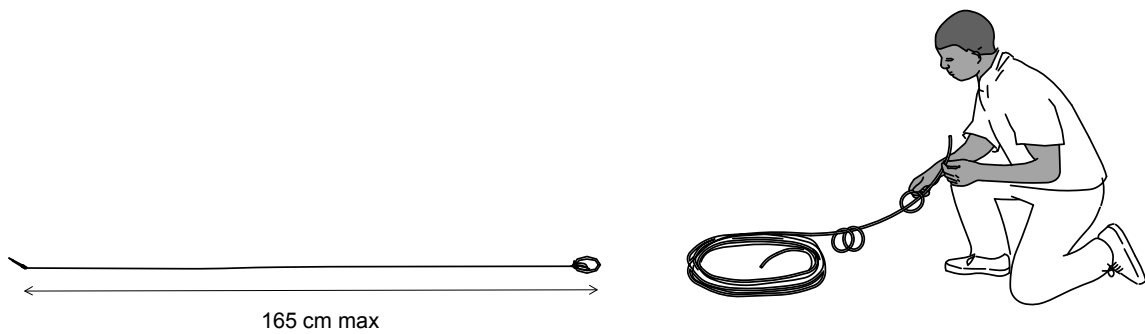

7.2

THE COMPASS CABLE

THE COMPASS CABLE - INSTALLATION

1

Remember to leave an opening in each gable wall!
Fix the cable at each end with a sturdy stick, then turn the sticks to stretch the cord taut.

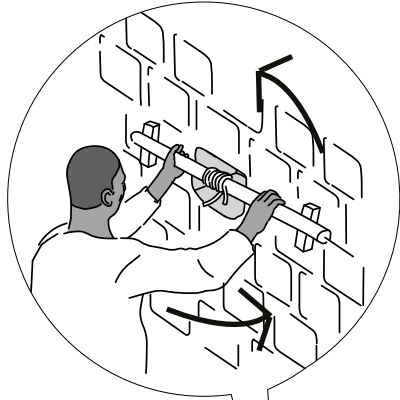

3

Each day, check with a spirit level that the cable is horizontal.



2

The cable must be centred

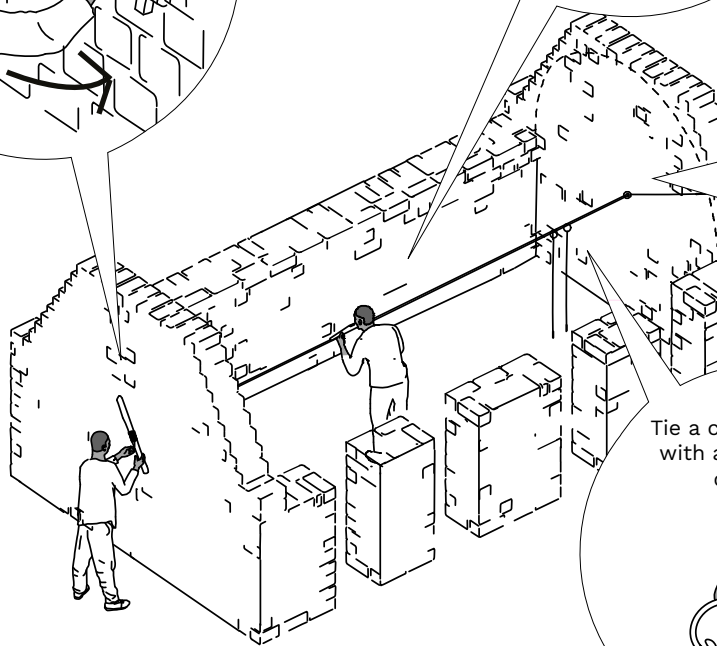
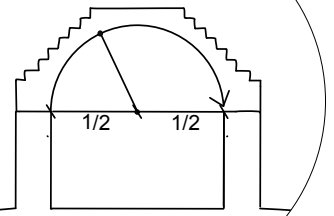

Tie a cord to each ring, with a nail at the end of the cord

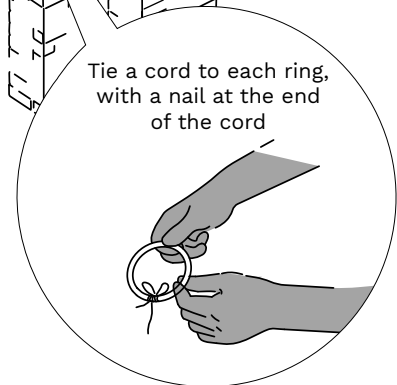

REMEMBER:

The cable must never be fixed either above or below the final height of the load-bearing walls!
FINAL HEIGHT OF THE LOAD-BEARING WALLS = HEIGHT OF THE BASE OF THE VAULT

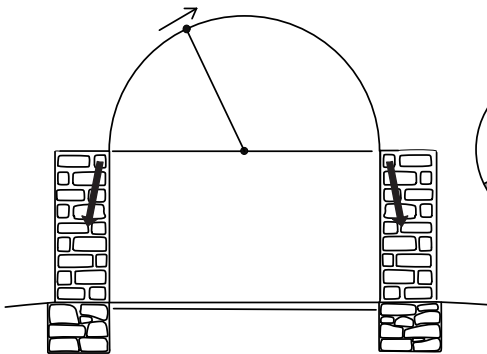

A round semi-circular arch,
load is taken by the walls = a stable vault.

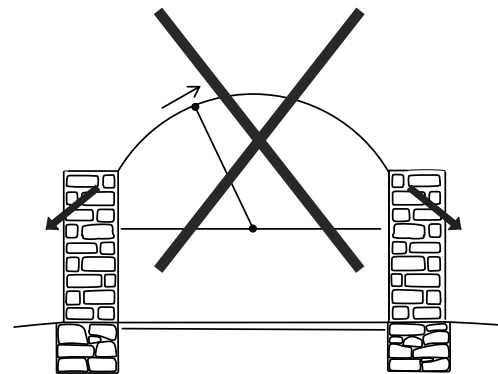

If the cable is lower than the the load-bearing wall,
the vault is flattened. The load pushes the walls sideways,
and the vault risks collapse!

8.1

ARCHES

FORMWORK FOR ARCHES

The lower part of the form-work is made with unmortared, loose, bricks, or with timber wedged in the brickwork. The rounded top is generally made using a barrel and a plastic sheet, but can also be made with loose bricks or a timber or metal form. In the latter case, take care to allow enough space on the inside.

1

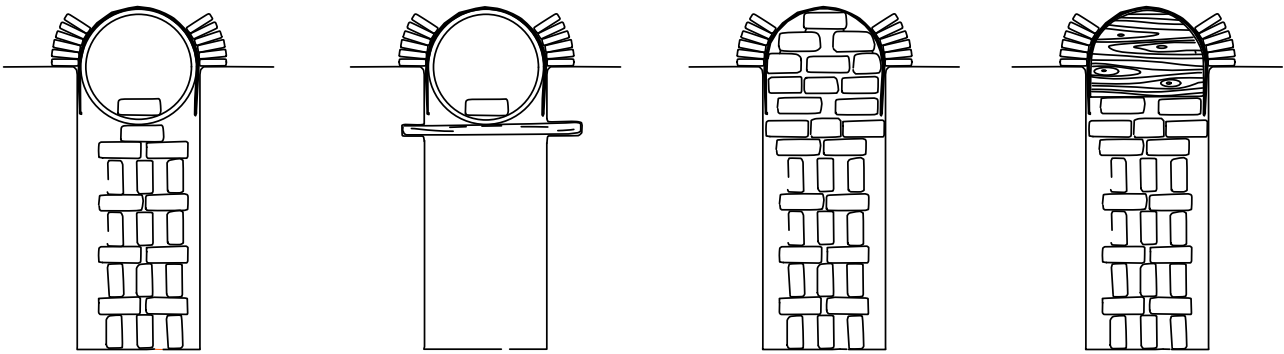

2

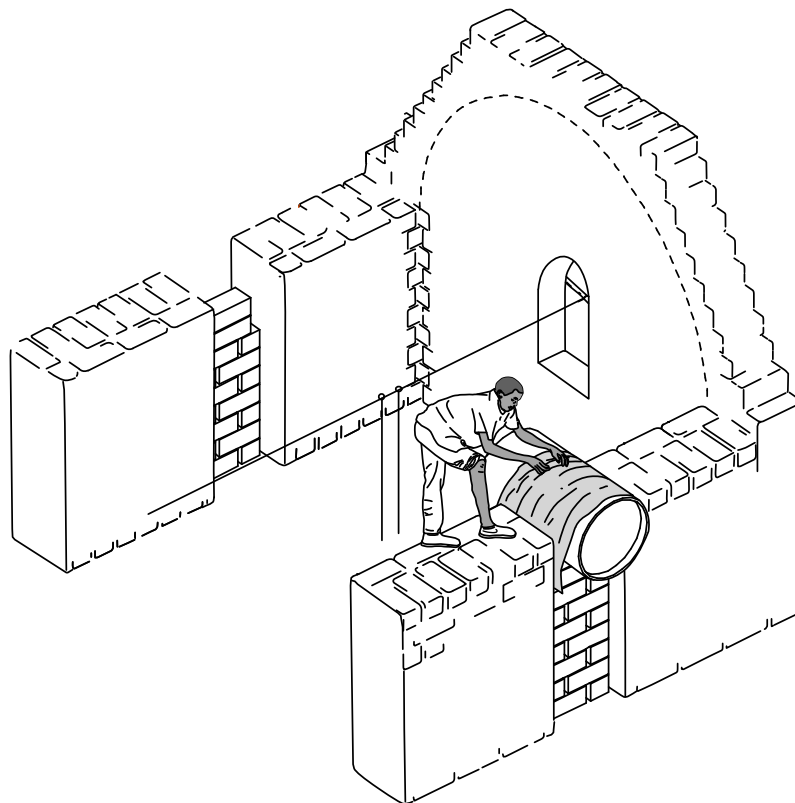

8.2

ARCHES

BUILDING THE ARCHES

3

The arch is built with two courses of small bricks.

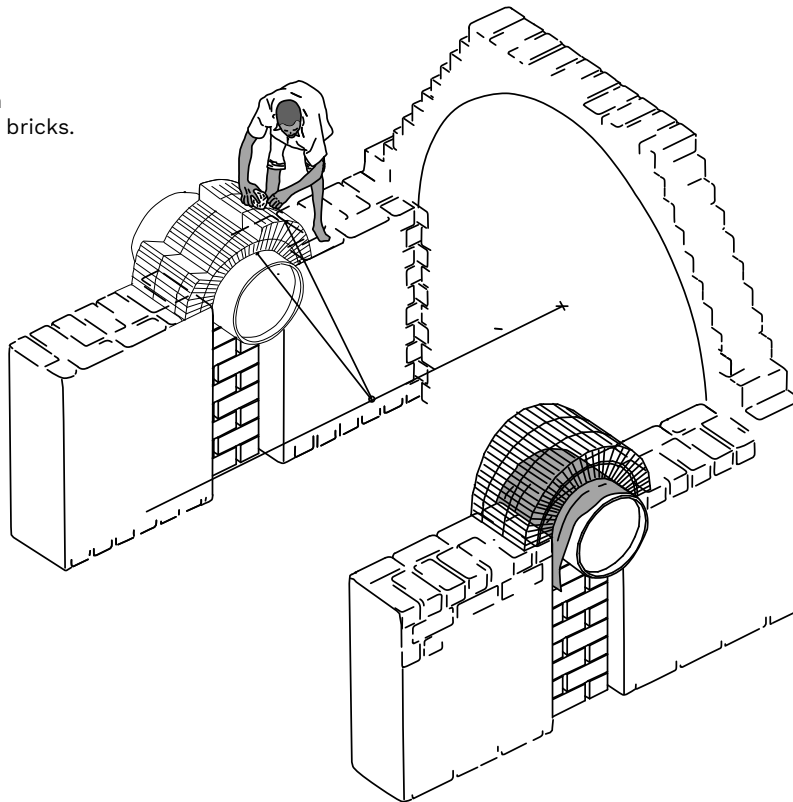

4

The arch follows the curve of the compass cable.
In the case of two vaults side by side, the arch is curved to each side.

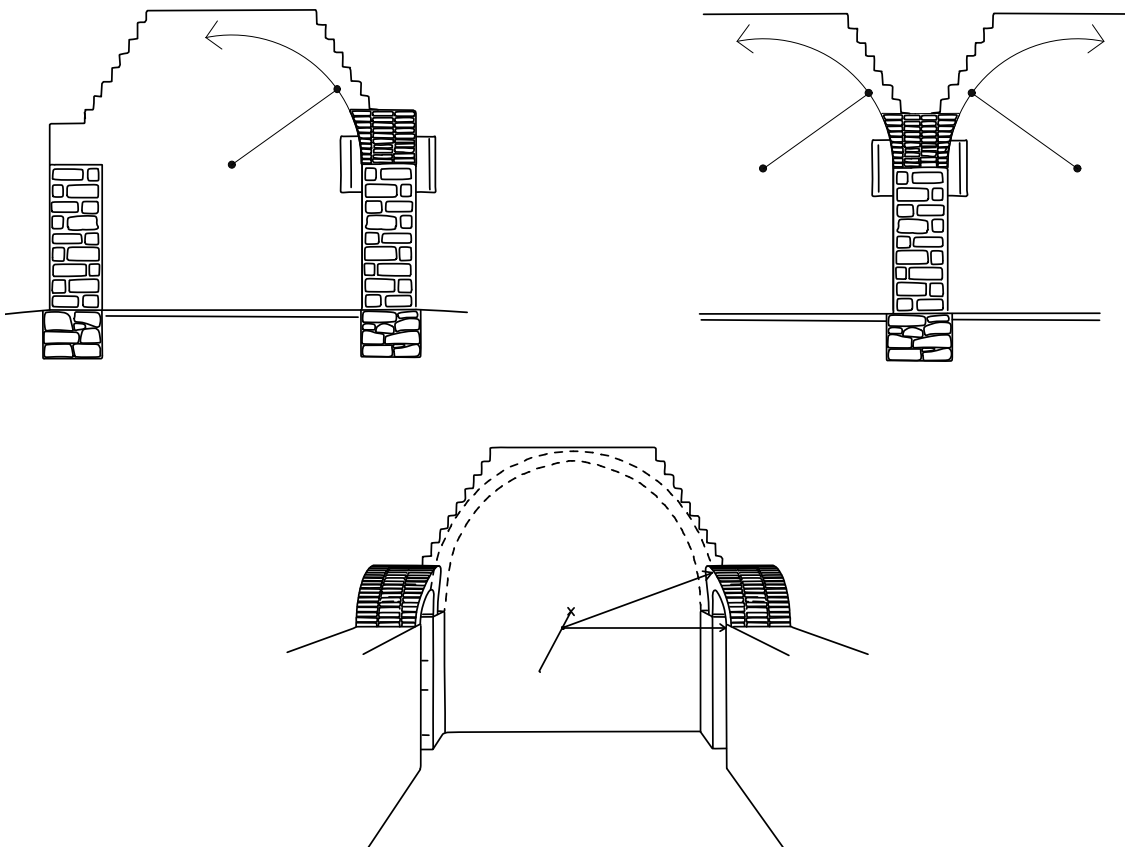

9.1

THE VAULT

STARTING THE VAULT

The vault must be built with inclined and crossed bricks, fixed with earth mortar.

The bricks must be moistened first, to ensure good adhesion (this also applies to the bigger bricks used for the walls) When starting the vault, the bricks need to be cut at an angle.

REMINDER:
> 3.3 for the vault dimensions.

WARNING:
always offset the rows

1

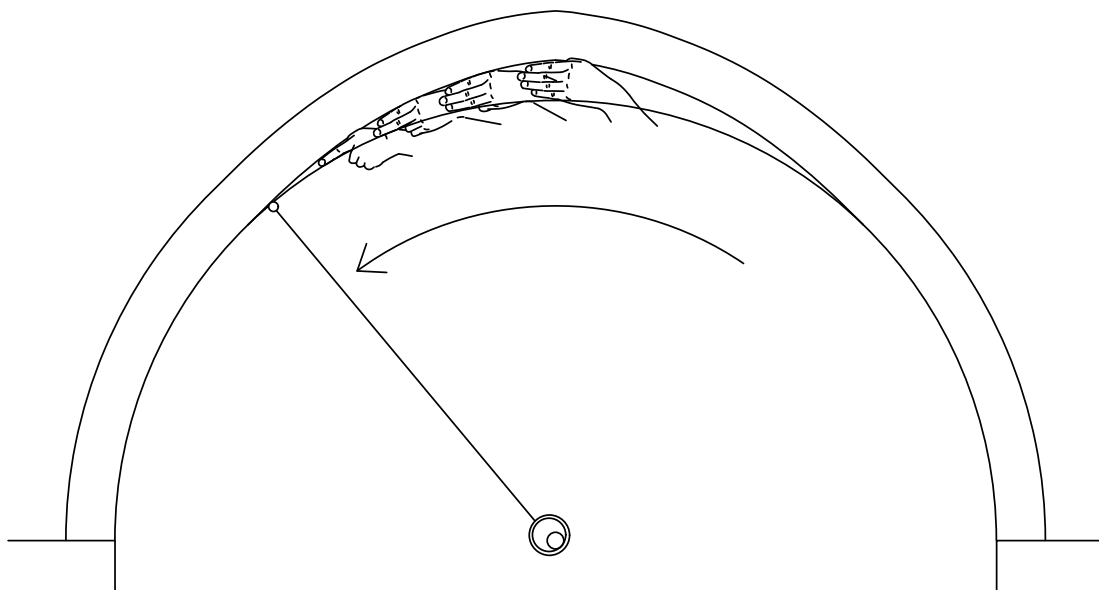
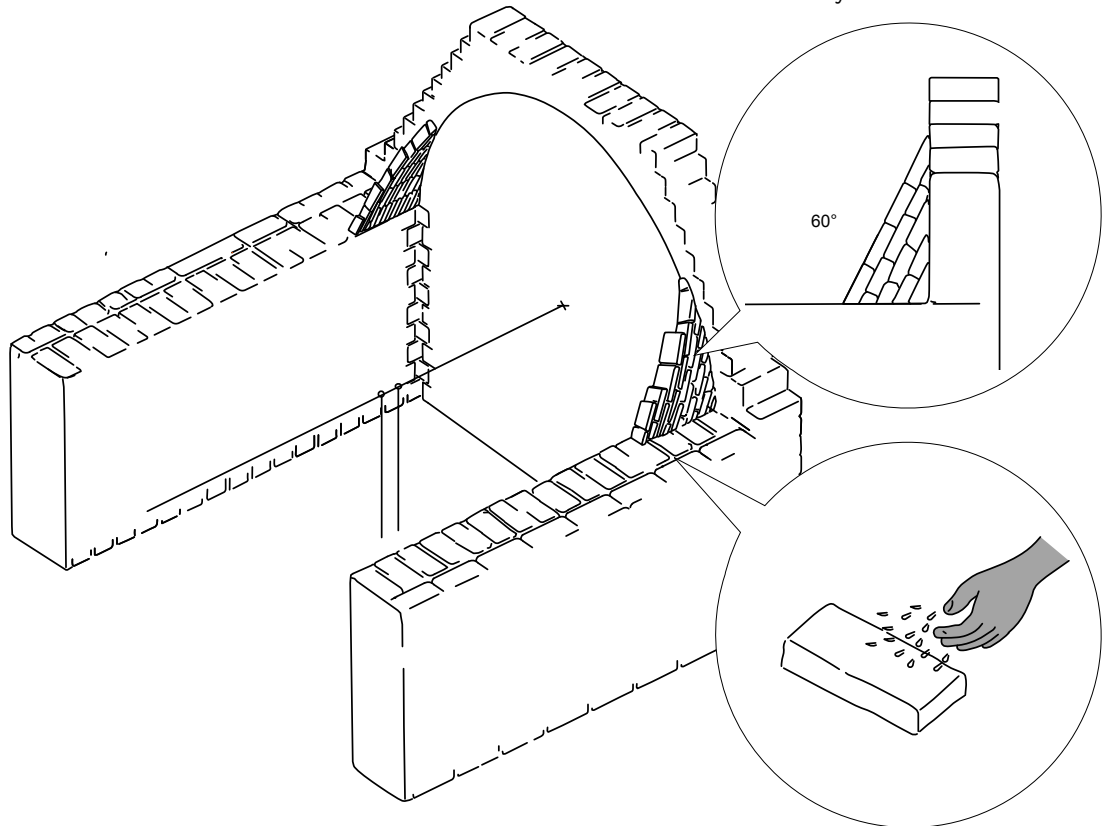

Base of the vault: semi-circular arc.
Top of the vault: offset of 1 finger, 2 fingers, 3 fingers, and finally 4 fingers at the peak of the vault.
Pull on the string to maintain constant tension.

9.2

THE VAULT

PROGRESSING THE VAULT

2

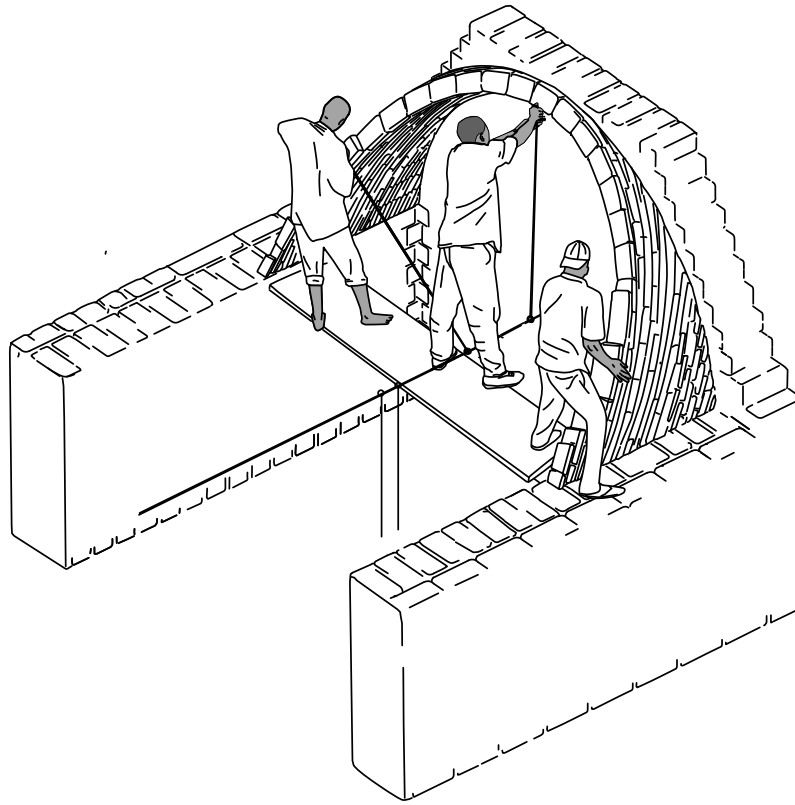

Step back regularly to check the correct slope of the courses of vault bricks.

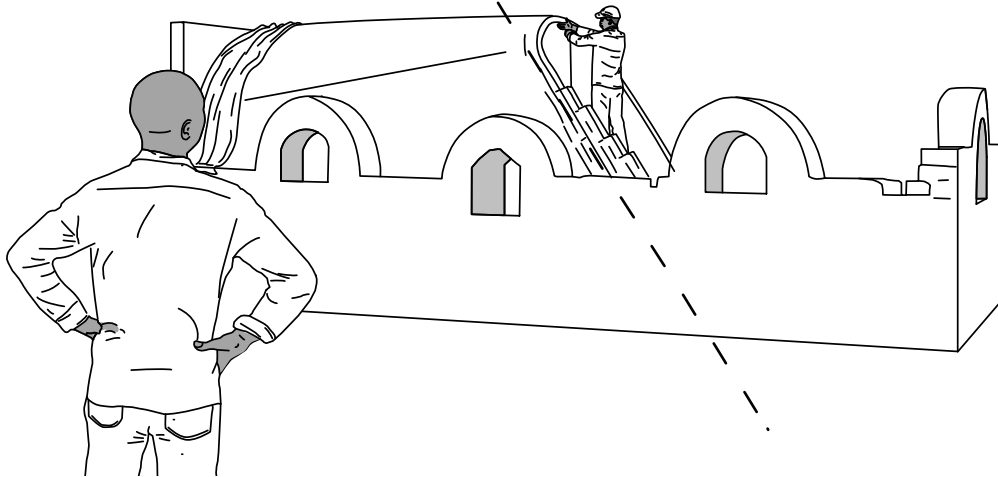

ADVICE IF A RISK OF RAIN

Fit a plastic tarpaulin over the vault which can be unrolled in the event of rain.

When working in a new region, the NV masons must first check on the local rainfall patterns, to avoid being caught out in the rain.

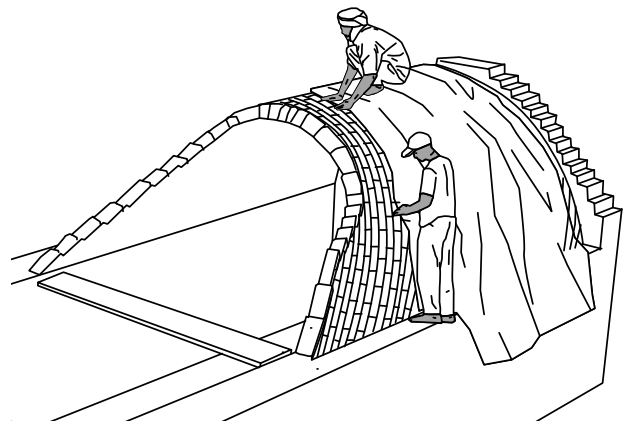

9.3

THE VAULT

CLOSING THE VAULT

Closing the vault is a delicate operation because of the awkward working positions. Take care to thoroughly check the the laying of the bricks, using the compass cable.

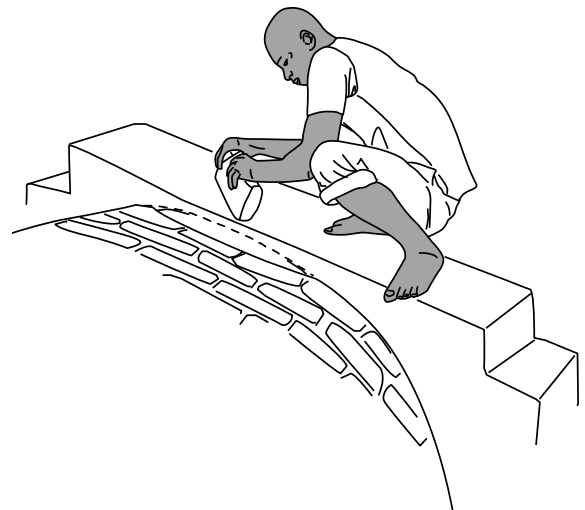
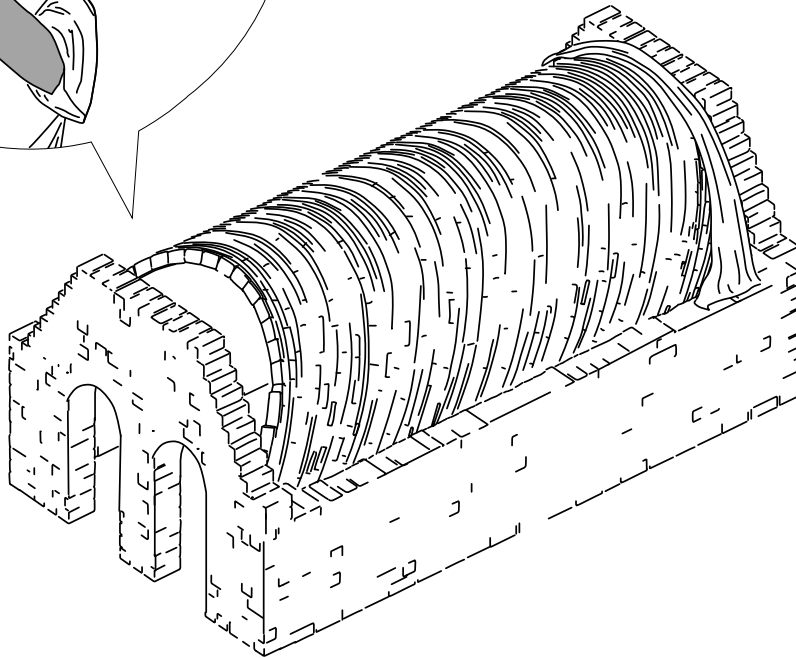

10.1

VAULT INFILL

LOADING THE VAULT

It is essential to carefully infill the gap between the vault and the side walls for ensuring the stability and strength of the vault. Acting as internal 'buttresses', the infills are built in the same way as the load-bearing walls, and should be raised together on each side of the vault.

1

Start in the corners

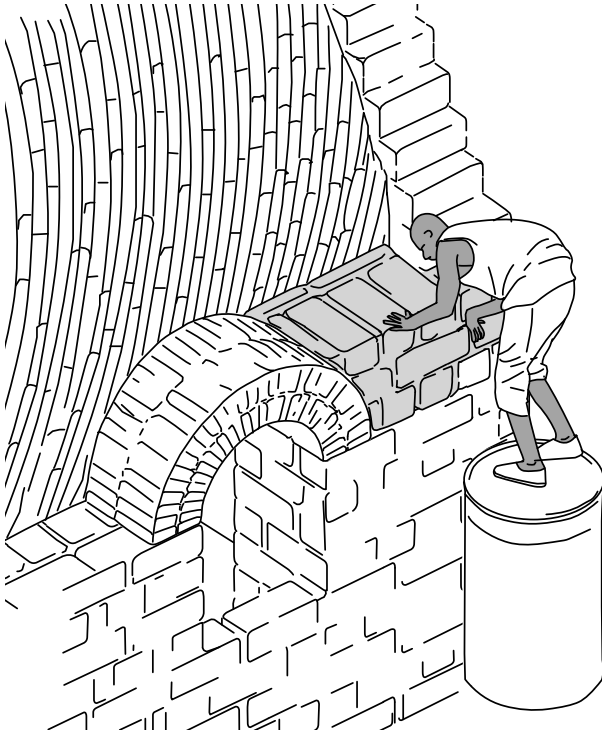

2

Raise one course at a time

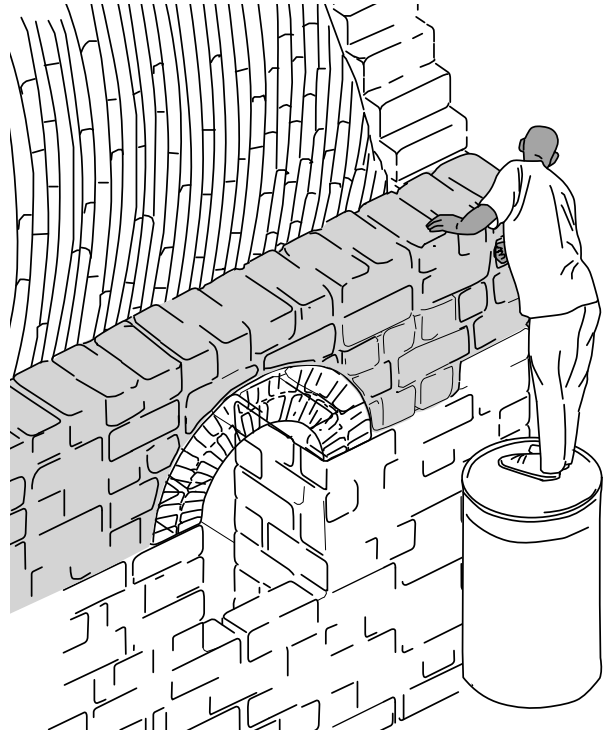

3

Check the verticality and alignment

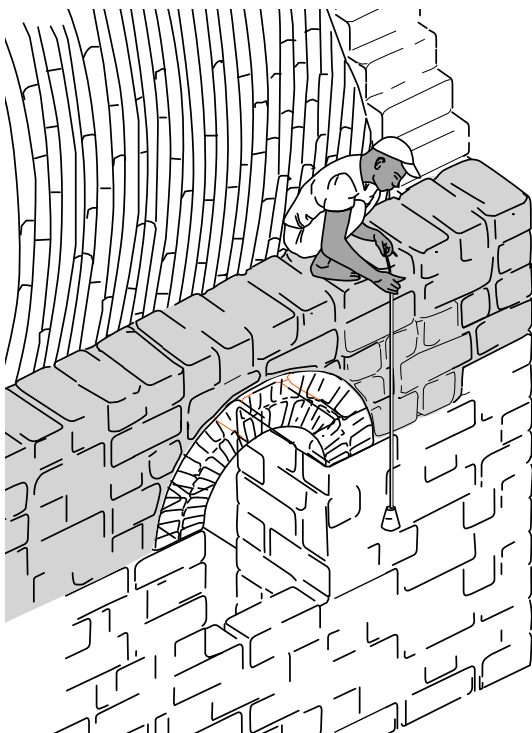

4

The infill 'buttresses' get wider as they follow the curve of the vault

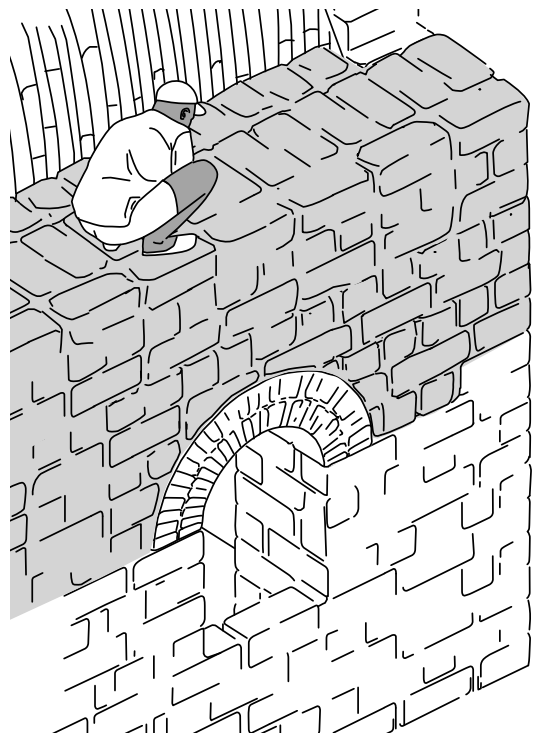

10.2

VAULT INFILL

LOADING THE VAULT

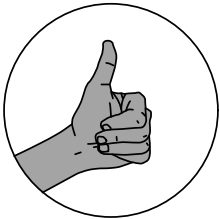
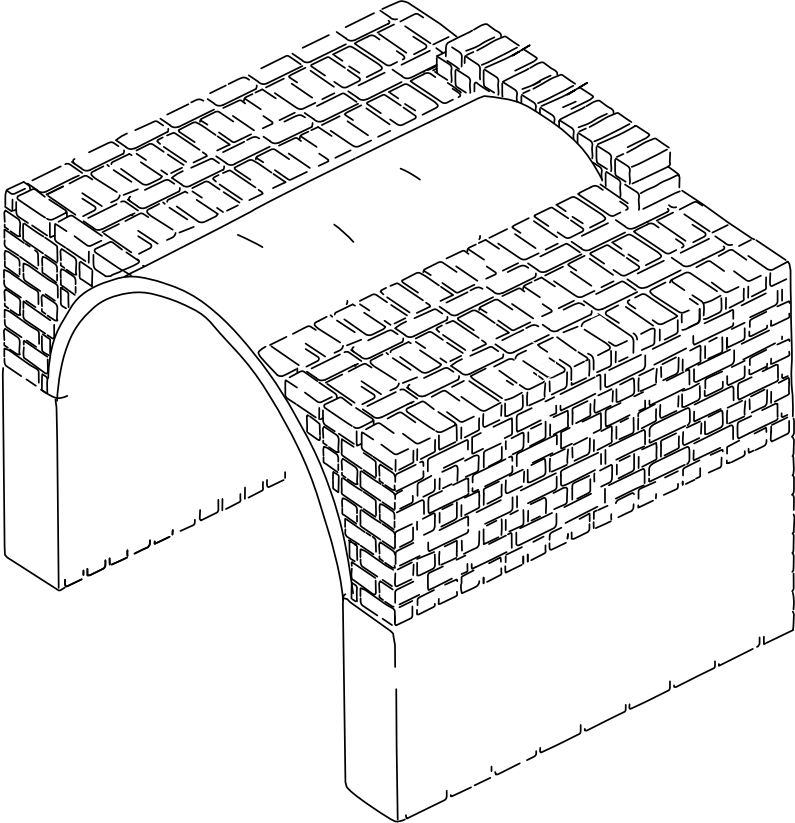

Load the vault with successive layers of bricks in a correct bonding pattern. Proceed at the same rate on both sides of the vault symmetrically.

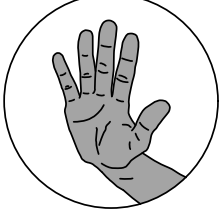
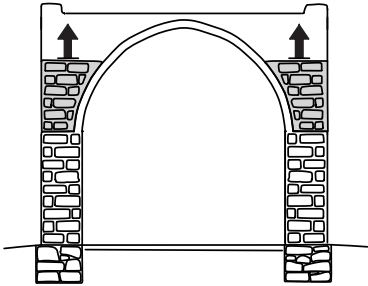

Do not fill the gap with loose rubble and bricks.

DANGER!

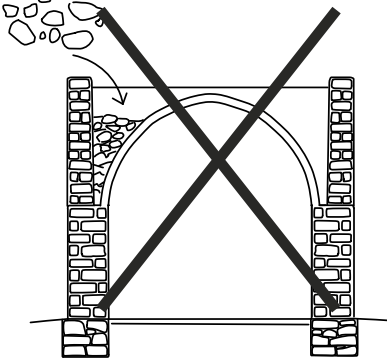

11.1

THE ROOF

ORIENTATION OF THE SLOPE (PITCH) OF THE ROOF

1

Standard case

The pitch of the roof (to drain off rainwater) is usually made along the length of the vault roof. It should not be longer than 10 m, and the top of the vault can be slightly visible towards the end of the slope. Whenever feasible, the gutters should not face into the prevailing wind.

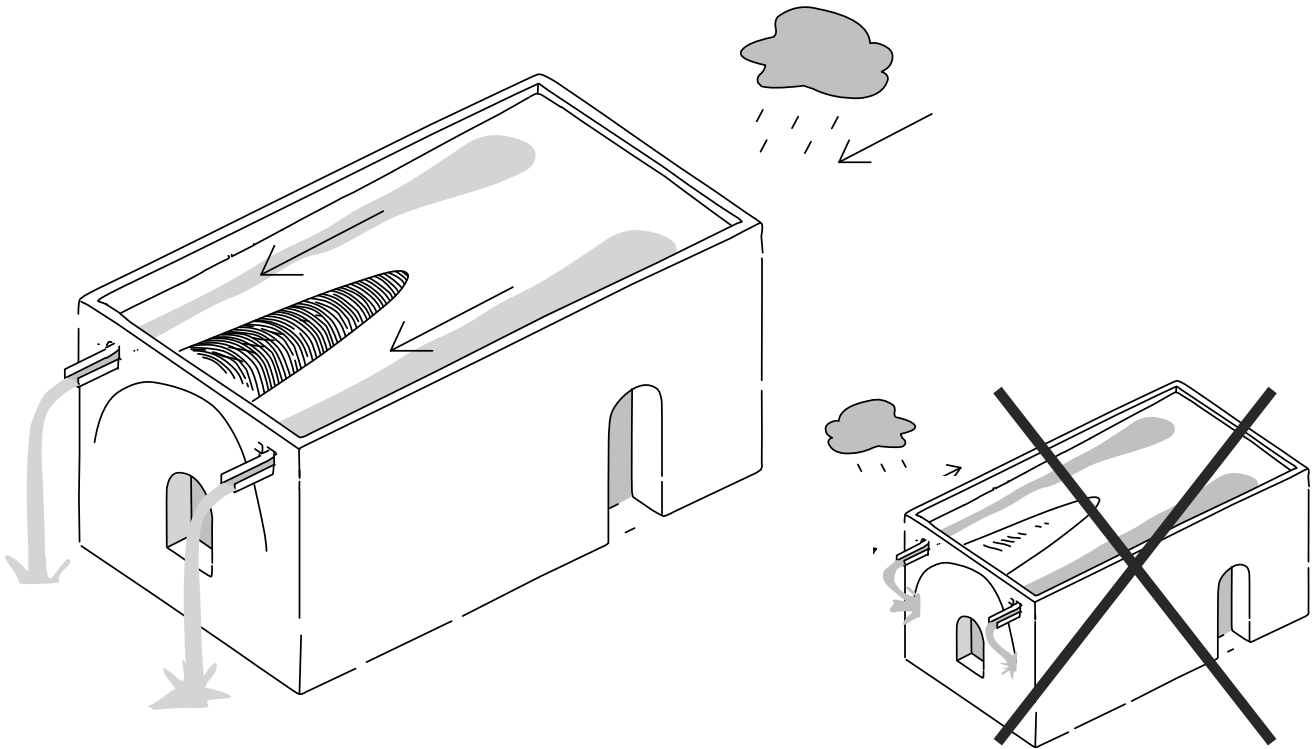

2

If necessary (other buildings close by, wind direction etc.)

If necessary, the pitch of the roof can be at right angles to the vault, in which case no part of the vault is visible.

TAKE CARE: it is more difficult in this case to ensure good drainage, so check that the water does run off towards the gutters and that there are no stagnant zones.

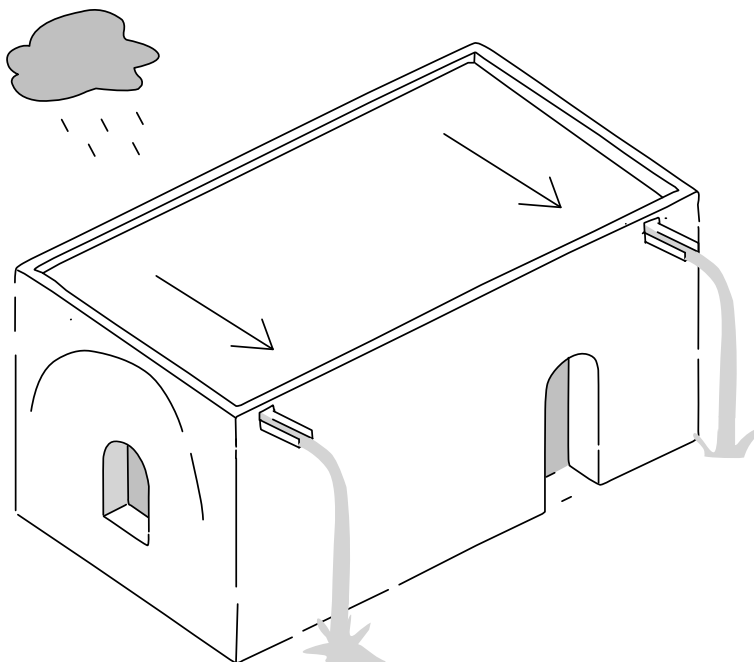

11.2-A

THE ROOF

MASONRY ROOF PITCH

1
Stop the infills one course below the top of the vault.

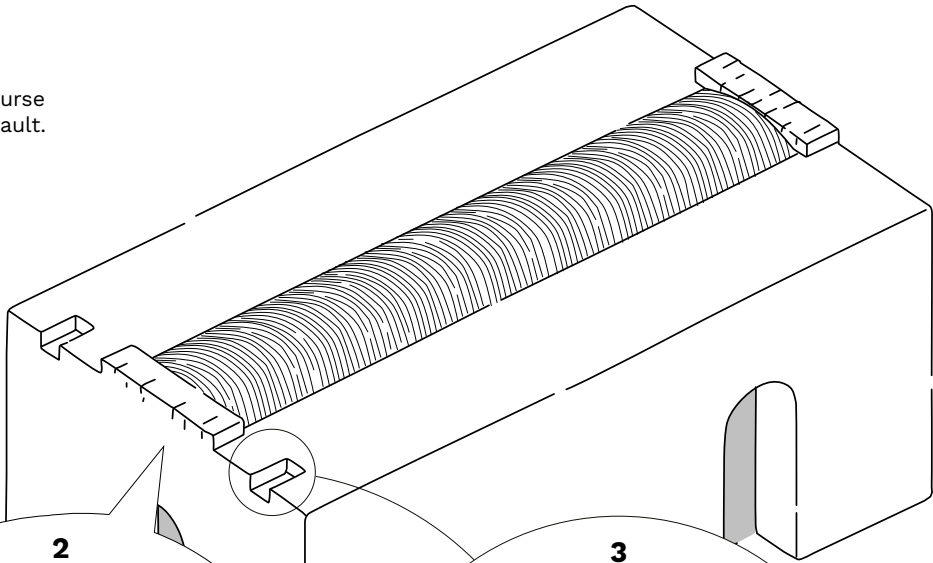

2
Round off the top edge of the gable wall at the lower end of the roof pitch.

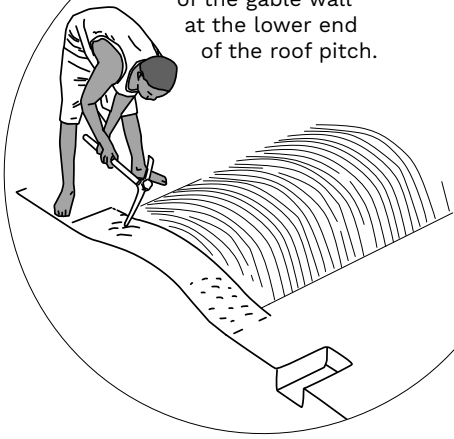

3
Cut out channels for the gutters.

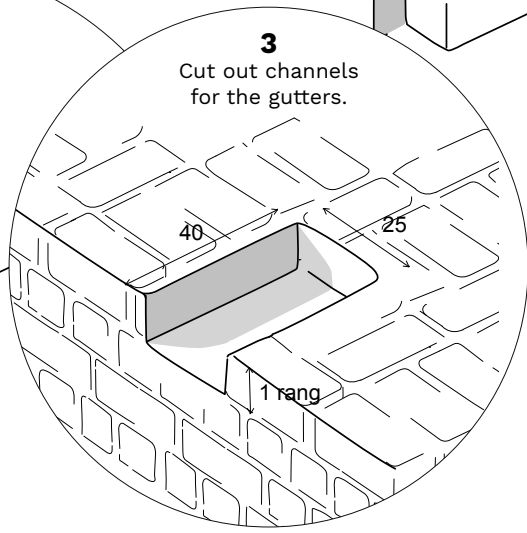

4
Raise a small wall of bricks at the high end of the roof pitch.
Calculate the number of courses according to the height of the slope.

Vault length	Slope height
max 10m	max 25cm
ideal 8m	ideal 20cm
6m	15 cm

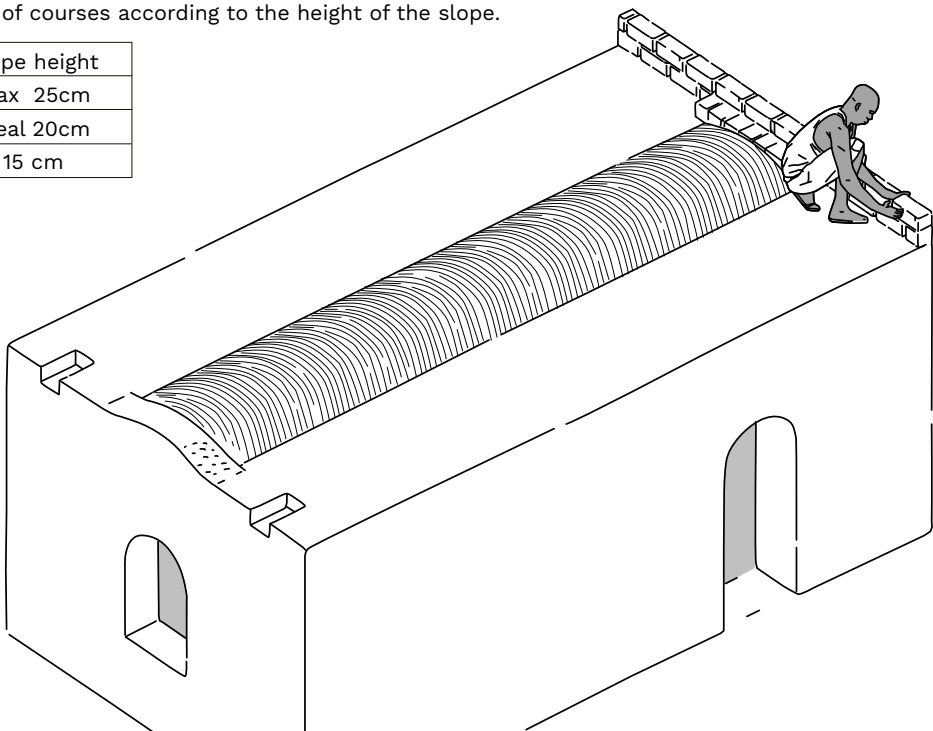

11.2-B

THE ROOF

MASONRY ROOF PITCH

1
Use weighted cords to define the slope of the vault. According to the depth of the slope, use whole big bricks, small bricks, and pieces of bricks, bedded with earth mortar.

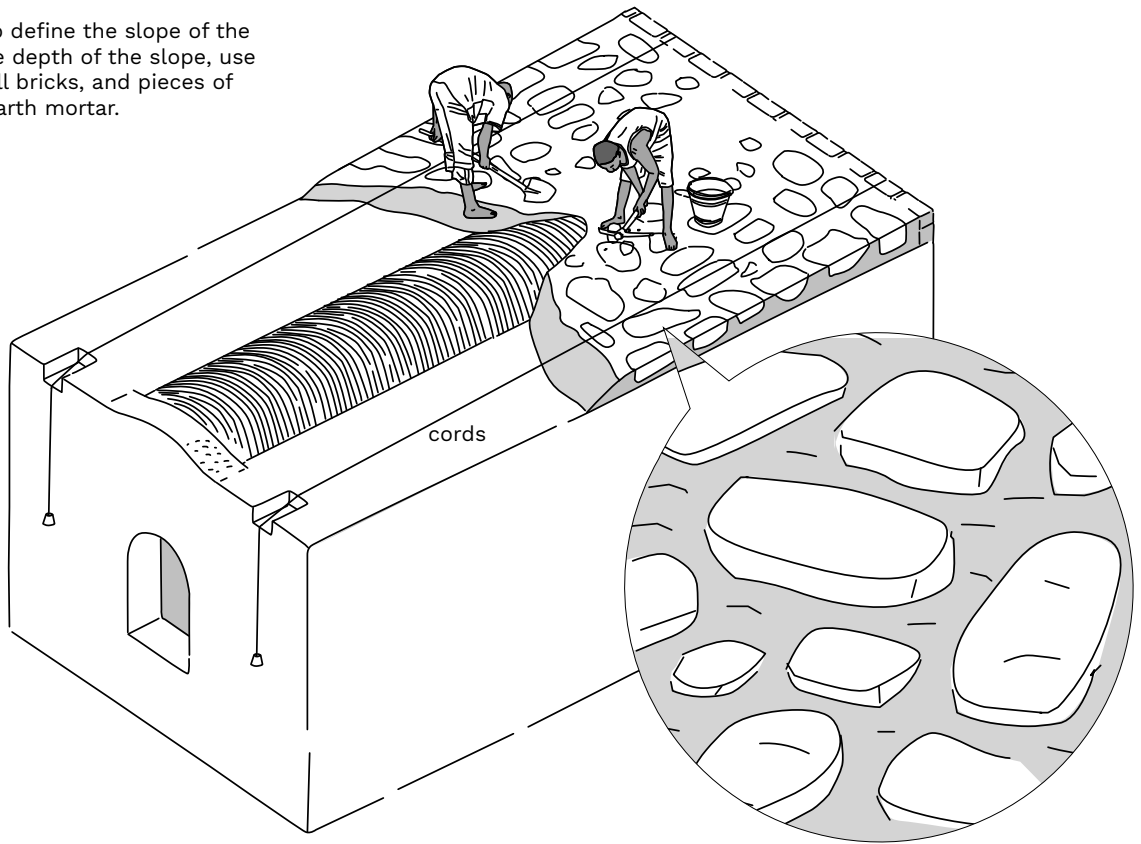

2
Smooth the completed surface with a layer of well moistened earth mortar, just a few mm thick.

IMPORTANT: check that the surface is regular, without any dips or bumps.

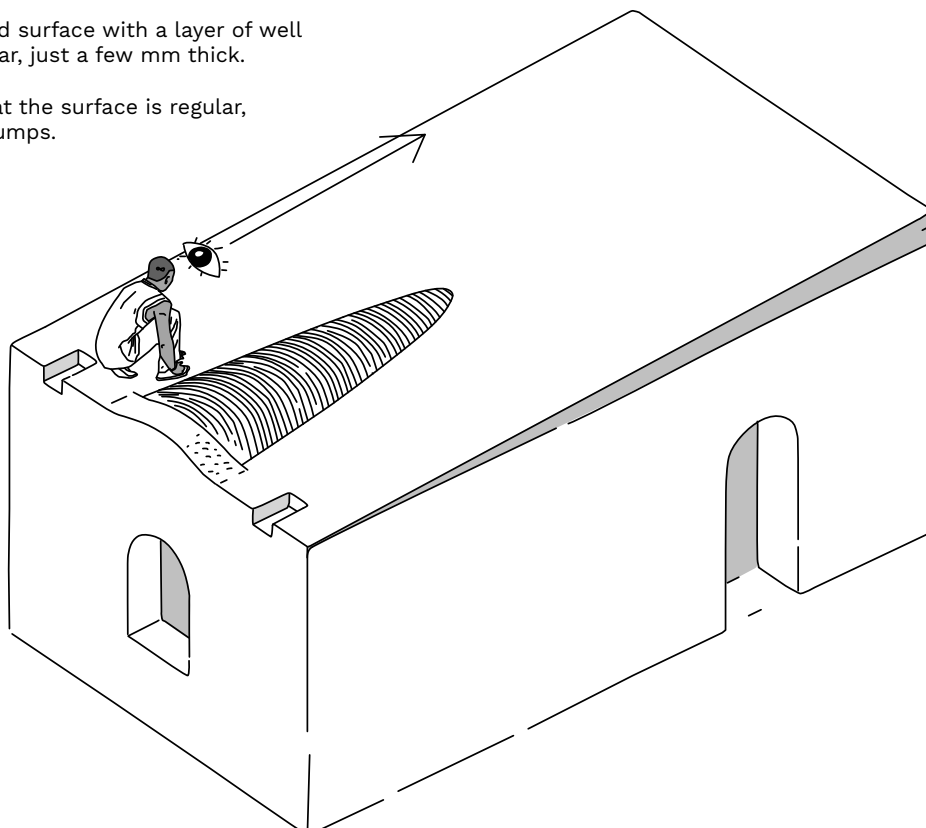

11.3-A

THE ROOF
GUTTERS

This page can be given to a metal worker
so that he makes gutters of the correct size.

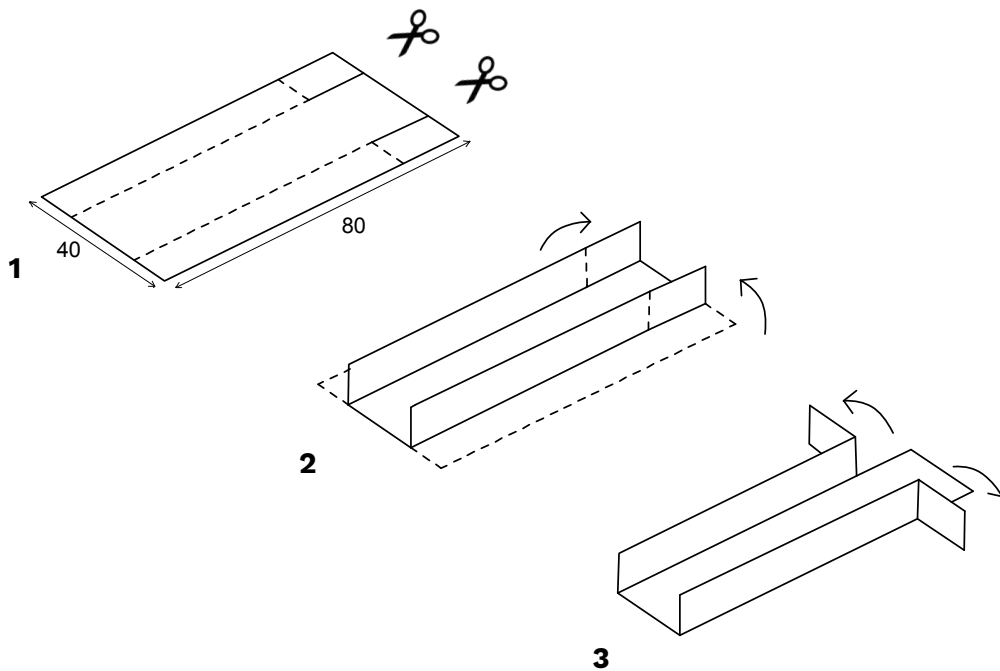
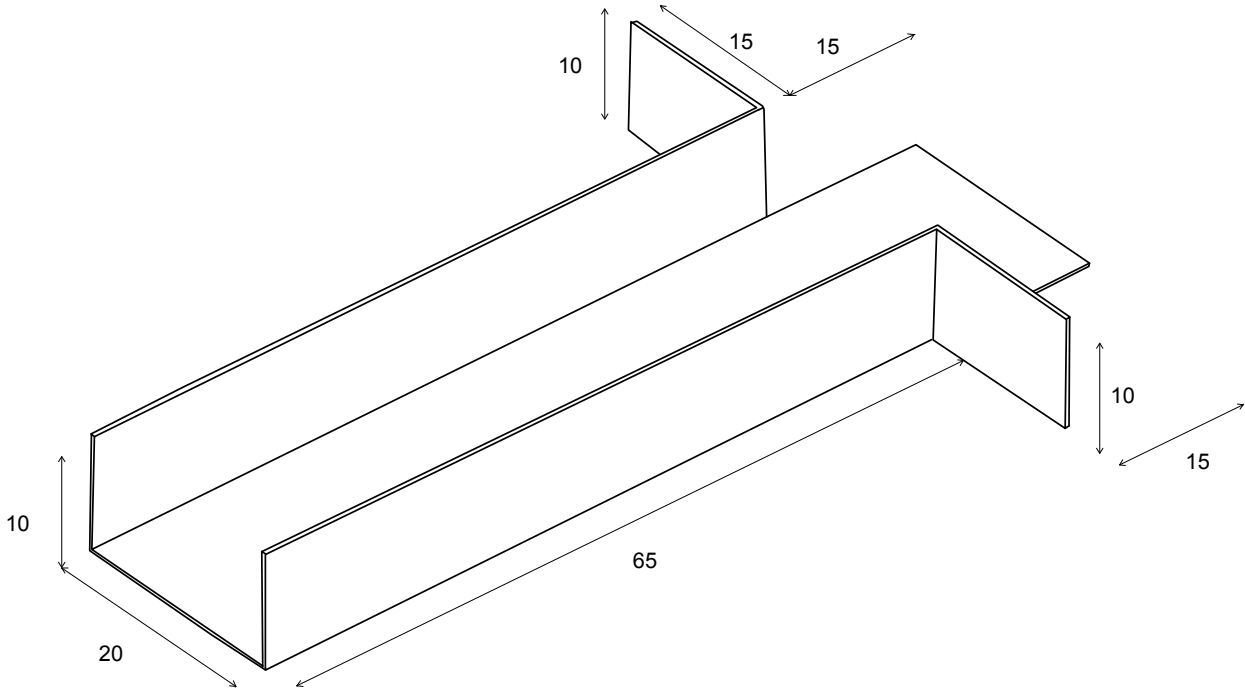

11.3-B

THE ROOF
GUTTERS

1

Cut out the channels for the gutters.
Remember to make two slots for the gutter flanges.
Cover the bottom of the gutter with a layer of cement mortar.

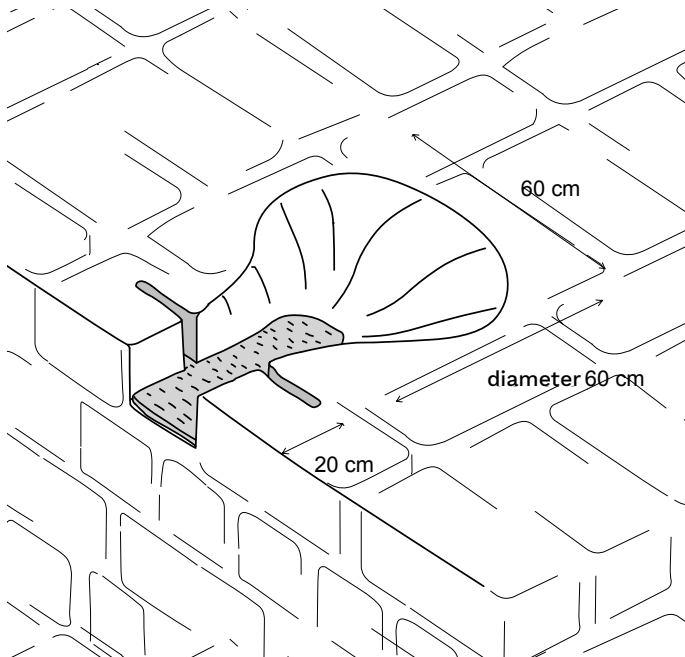

2

Insert the gutter.
Follow the measurements in the drawing:
the gutter should project by 45 cm.

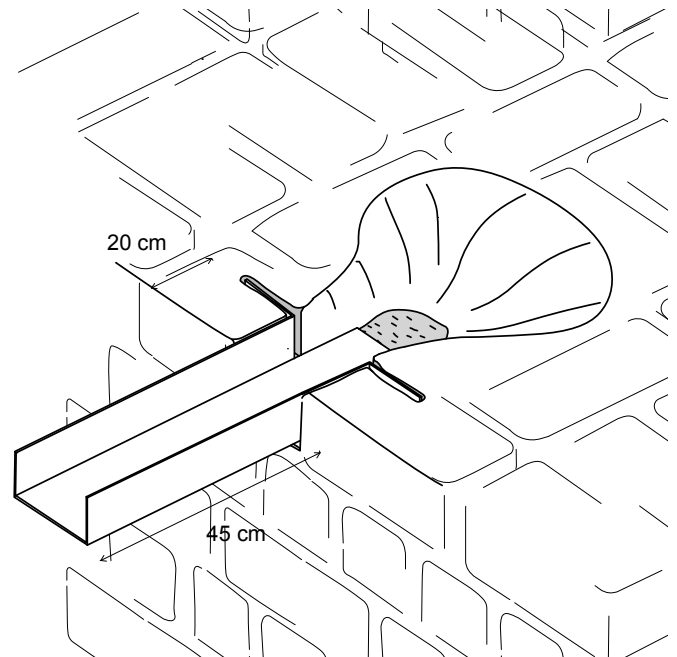

3

Check:
- the slope of each gutter
- that they are parallel to each other

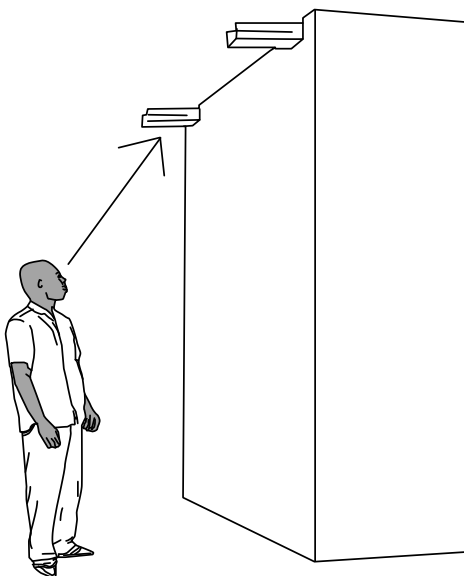

4

Fix the gutter with cement mortar.
The finishing render will eventually cover the layer of cement.

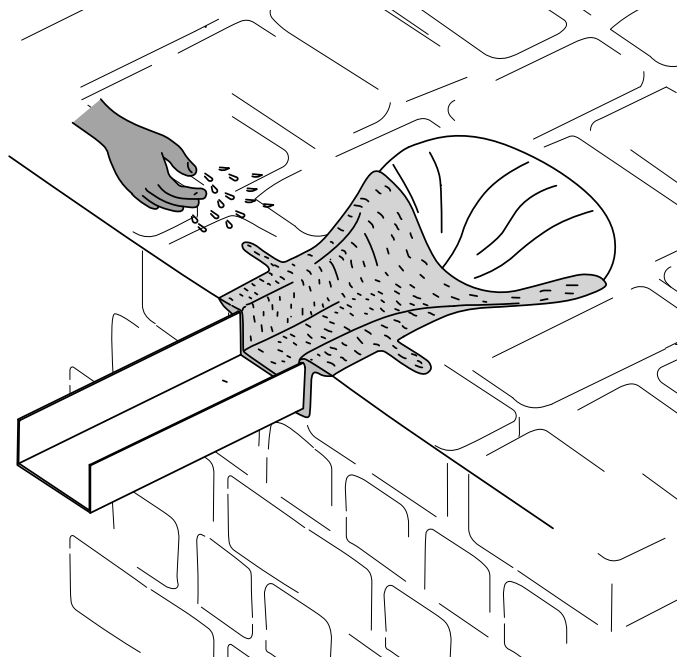

11.4 - A

THE ROOF

WATERPROOFING - PLASTIC SHEET AND LAYER OF BANCO

1

Use plastic tarpaulin - double-width where possible so as to reduce the number of strips and get a good coverage / folding of the strips. Cut the strips to the correct length (the width of the roof) and roll them up before taking them onto the roof.



2

Unroll the first strip at the gutter (lower) end of the roof. Make folds to allow for the gutter holes.

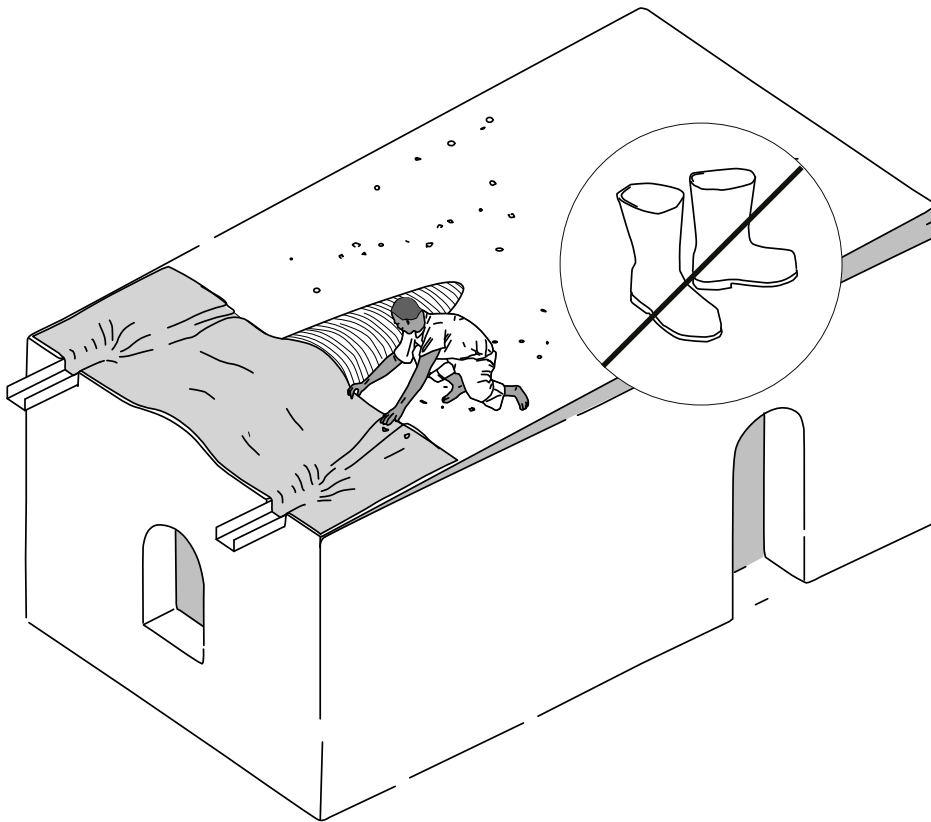

REMEMBER:

The plastic sheet must not overlap the wall!

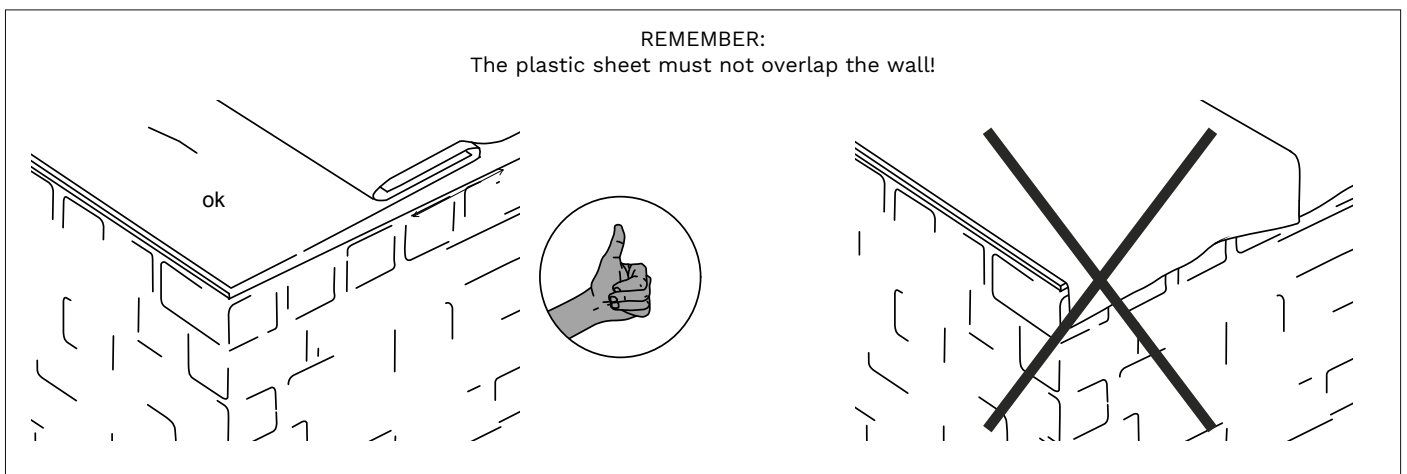

11.4 - B

THE ROOF

WATERPROOFING - PLASTIC SHEET AND LAYER OF BANCO

3

Install the second strip, overlapping the first one by at least 20 cm, and folded over the join. At the same time, put down a layer of banco of 7- 8 cm to stabilise the first strip.

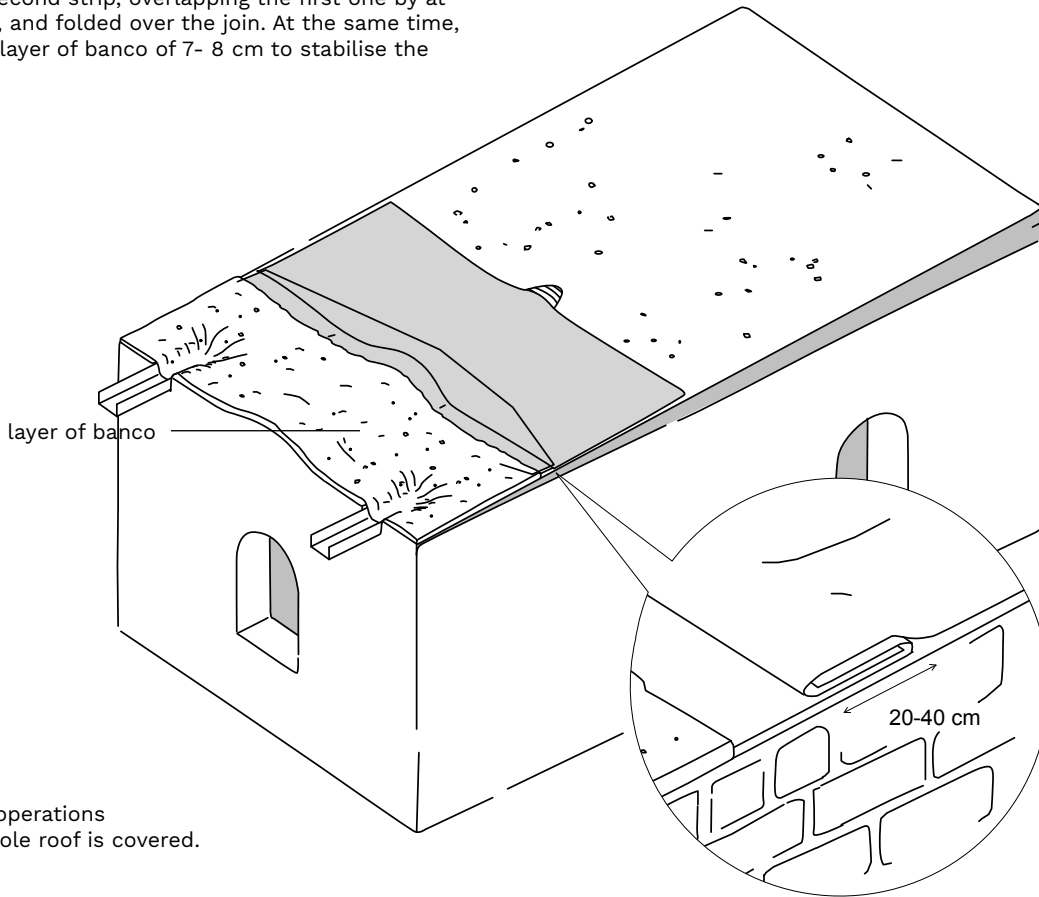

4

Repeat the operations until the whole roof is covered.

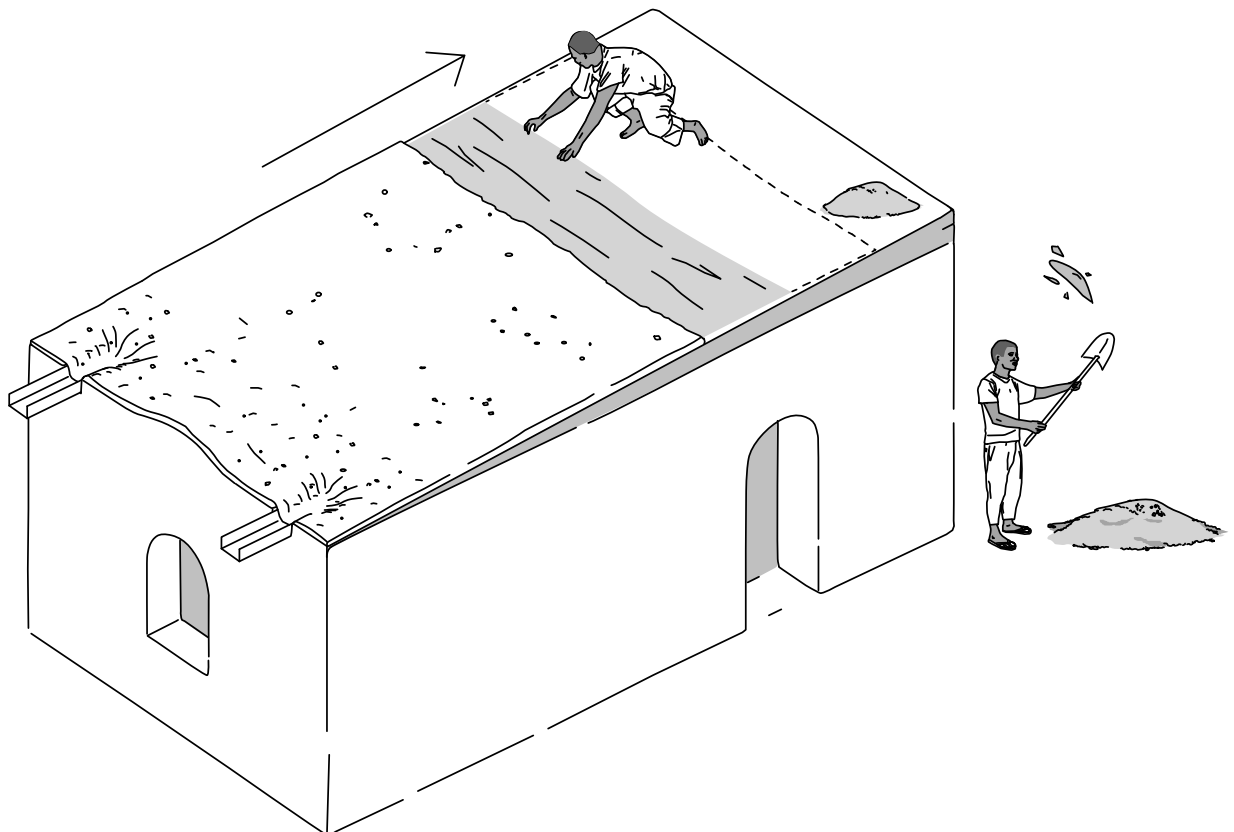

11.4 - C

THE ROOF

WATERPROOFING - PARAPETS

The parapets can be built with standard mud bricks or with special bricks (> 1.2).

- 1**
Start in the corners, check the verticality, and stretch cords to get a correct horizontal level.

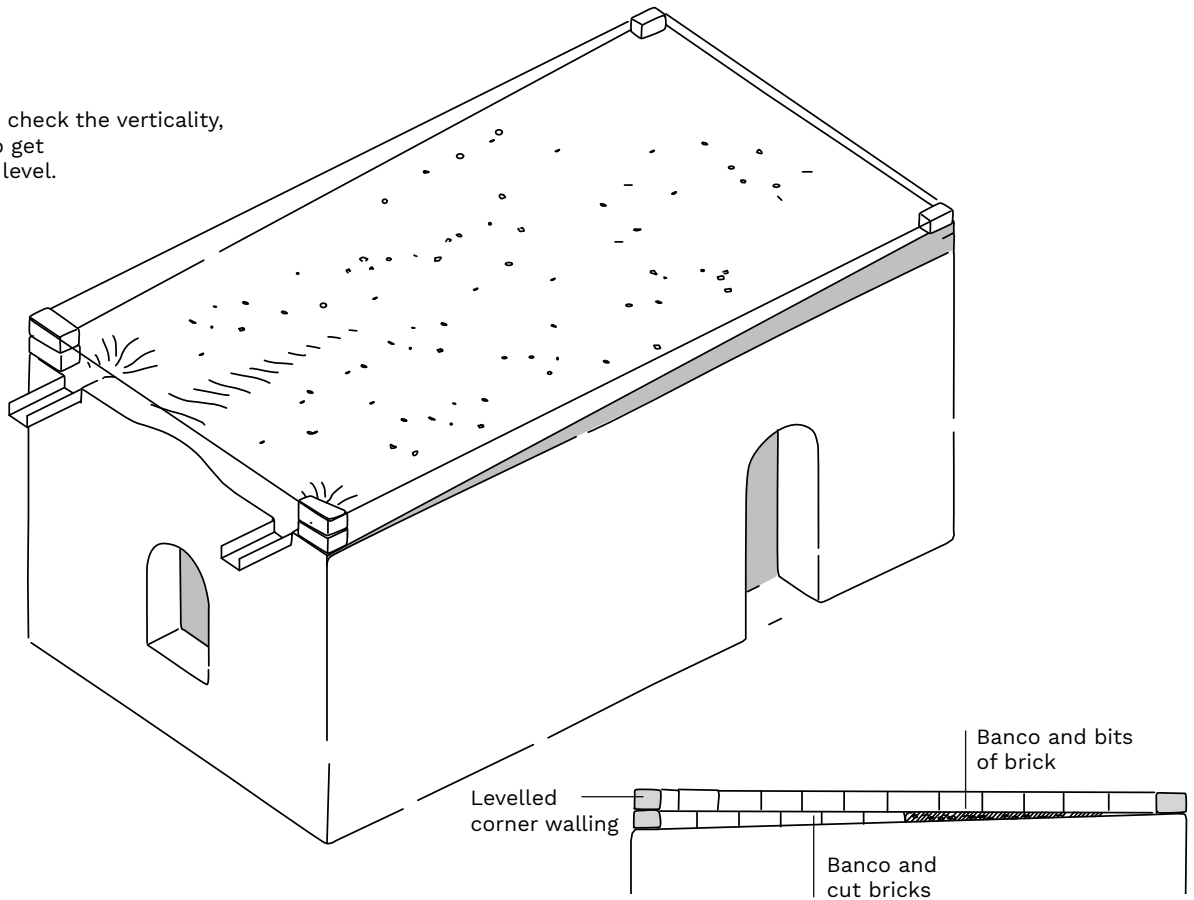

- 2**
Build the parapet walling, leaving a gap for the gutter exits.

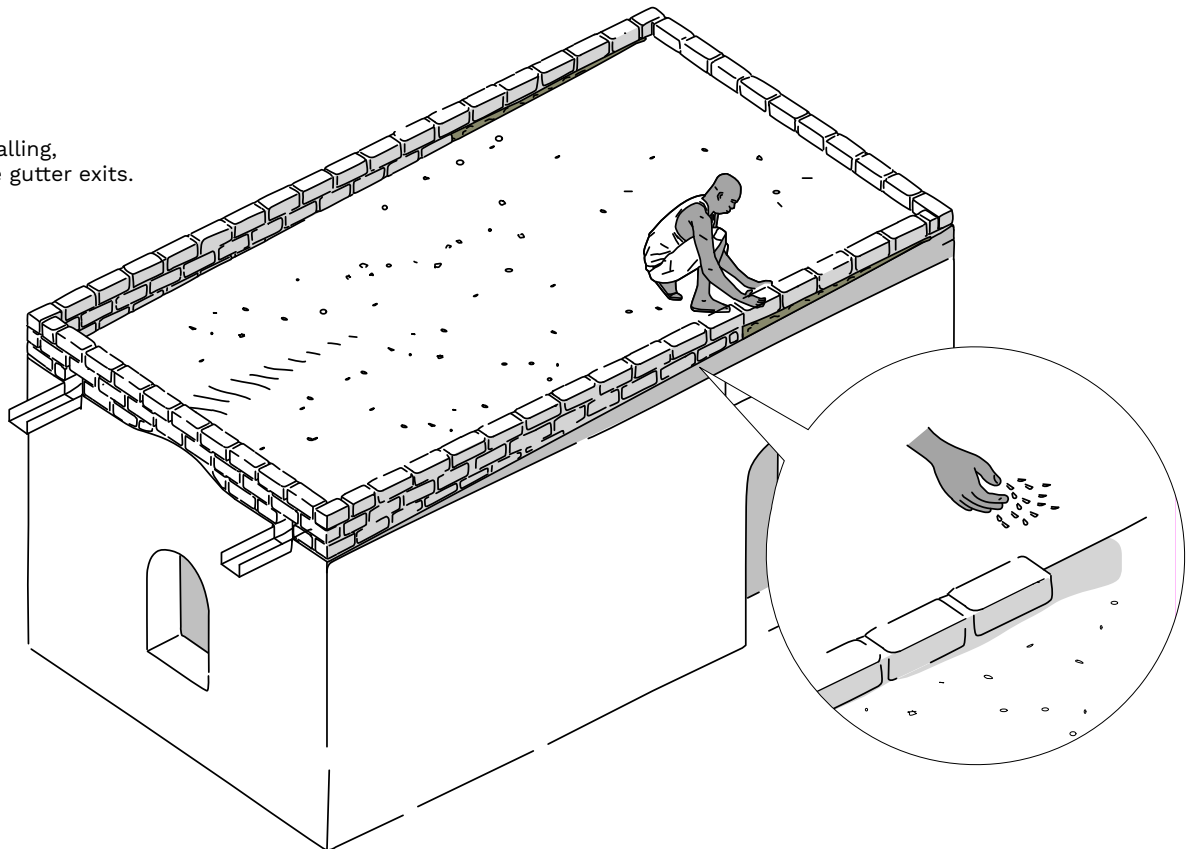

11.4 - D

THE ROOF

WATERPROOFING - FINISHES

1

Apply a finishing render on the roof (banco, compacted earth, bitumen... > 22.3 and 22.4) of varying thickness depending on the chosen render:

- go right to the end of the roof at the gutter end
- smooth with water, tamp, and compact
- remember to check the gradient / slope.

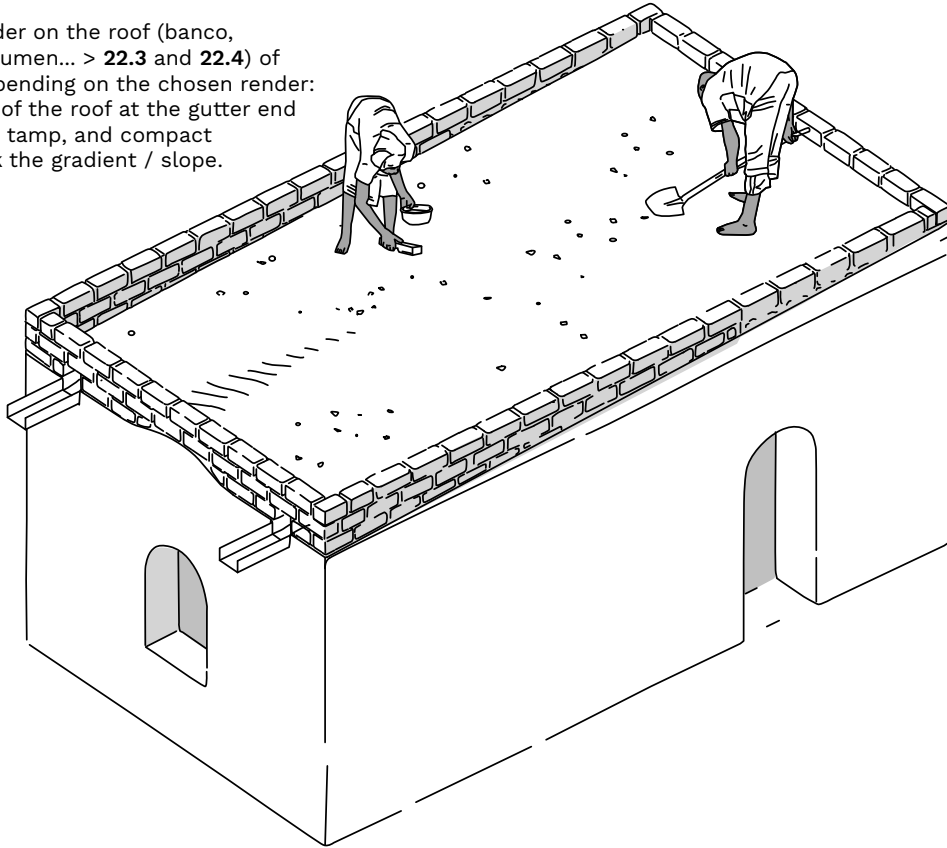

2

Check for stagnant pools and leaks around the gutters
IMPORTANT: this stage is extremely important. Water is the main cause of problems with the roof and the entire structure!

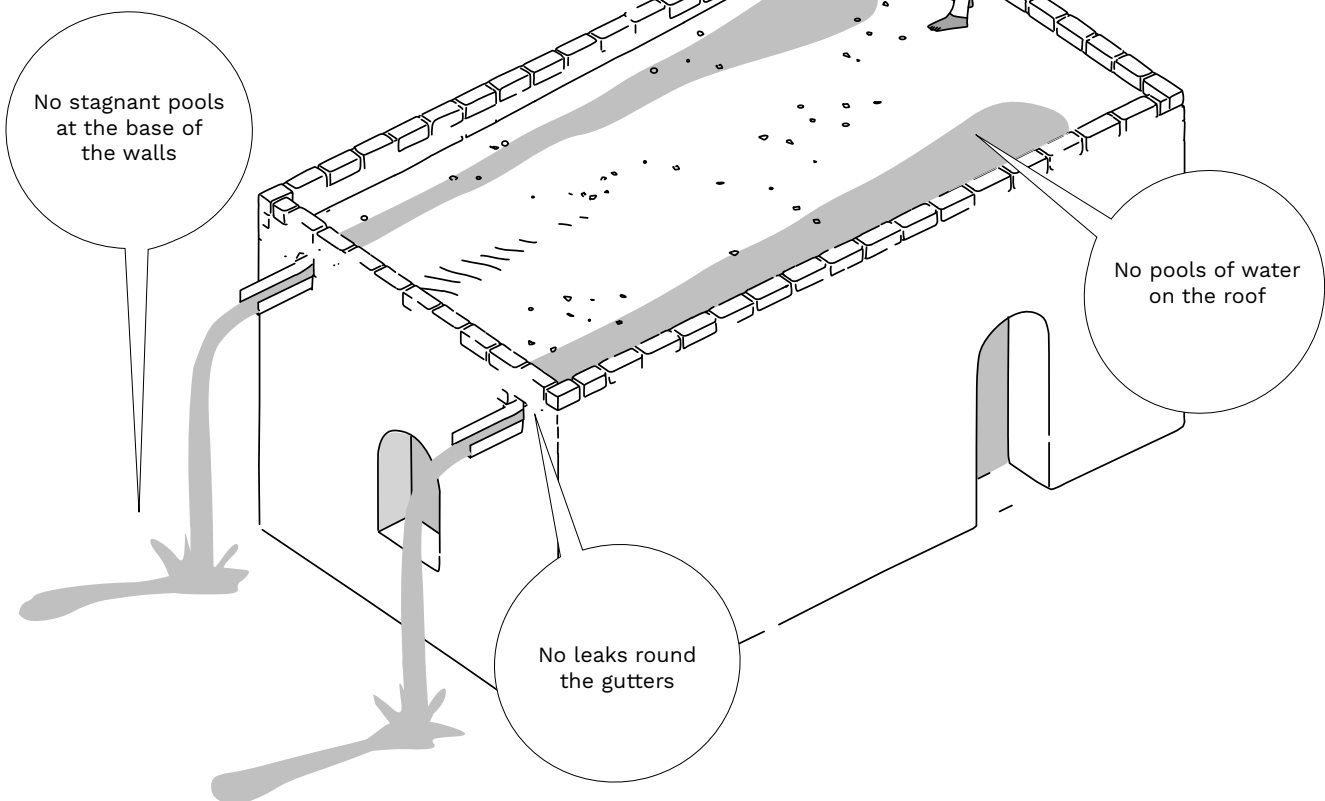

11.5 ★ AD

THE ROOF

ENCASED RAINWATER DOWNPIPES

PHASE 2

12.1 - A ★ AD

PARAPETS

PROTECTION WITH CEMENT SLABS - THE MOULD

1

Making the mould

The mould is made with square 40/40 metal tubes. Make a slit for the rainwater drip 2.5 cm from the edge.

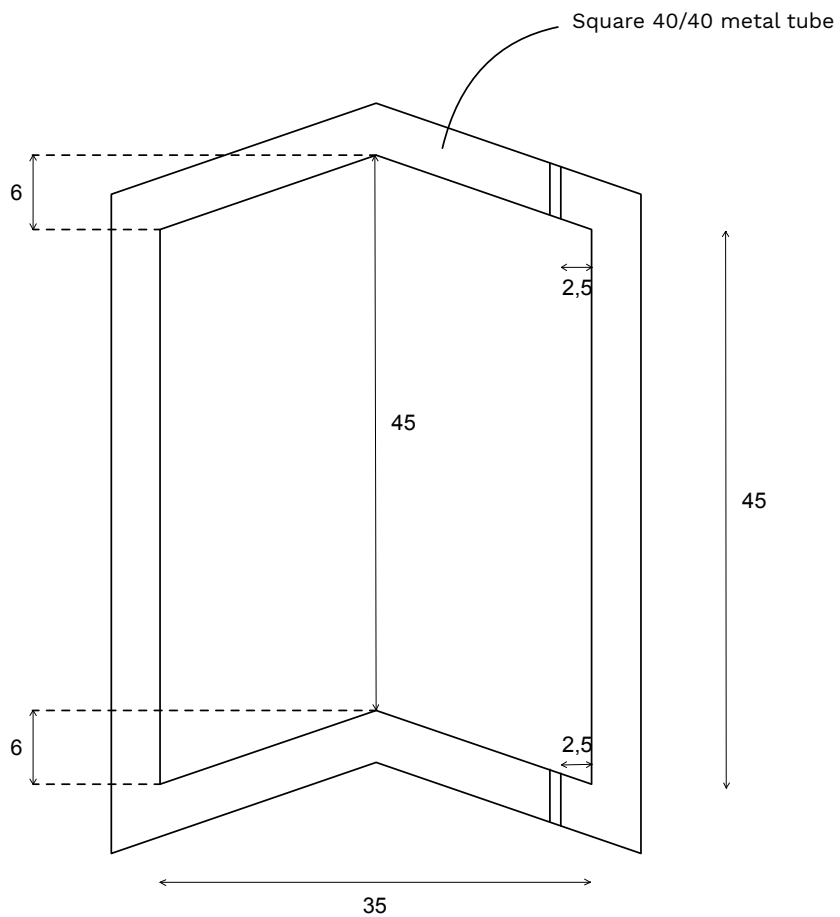
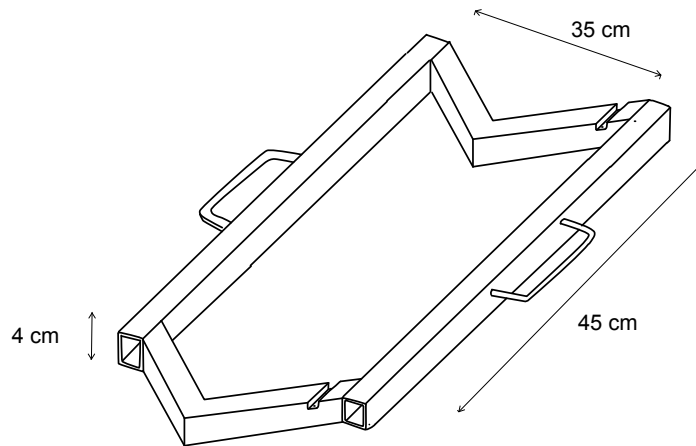

12.1 - B ★AD

PARAPETS

PROTECTION WITH CEMENT SLABS - FABRICATION

Parapets are very exposed to rain. Protecting them with cement top slabs also reduces the need for maintenance.

RECOMMENDED MIXES FOR 25 SLABS

Cement	Fine sand	Gravel	Water
50 kg	2 wheelbarrows	2,5 wheelbarrows	25 litres
			

1

Making the slabs

Fill the mould with cement mortar; score the surface with a trowel; make the rainwater drip channel with an 8 mm diameter iron reinforcing bar; take great care in lifting off the mould.

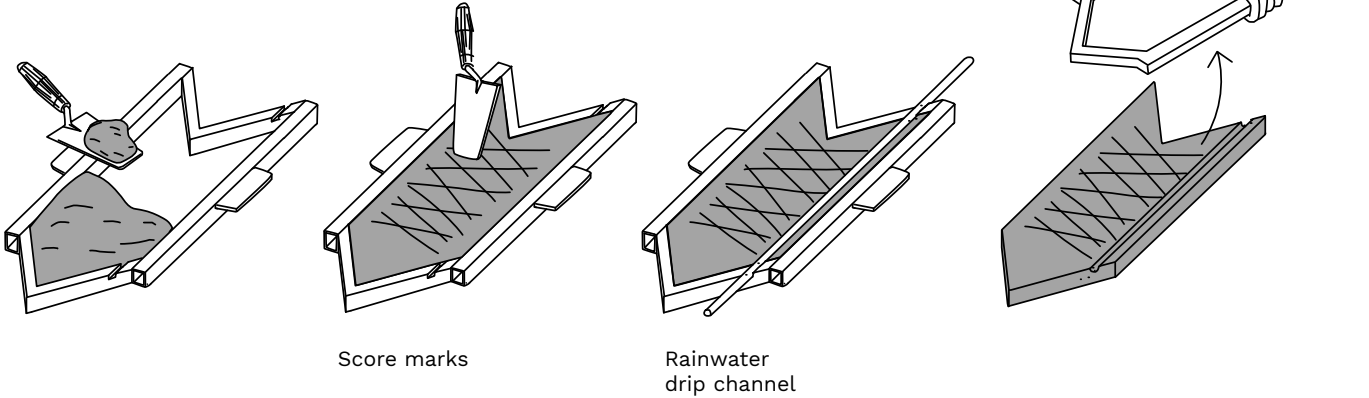

2

Making corner and half slabs

Cut the damp cement with a trowel to make the corner and half slabs.

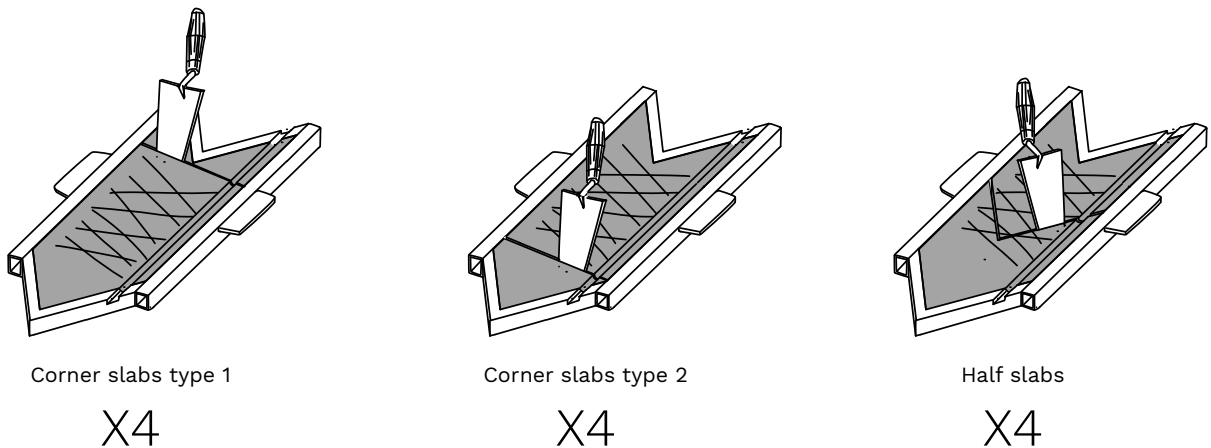

12.1 - C ★AD

PARAPETS

PROTECTION WITH CEMENT SLABS - LAYING

The parapets are very exposed to rain. Laying cement slabs on them both protects them and reduces the need for maintenance.

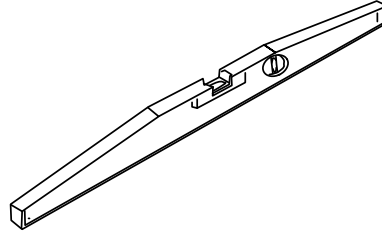

1

Start by laying the corner slabs and checking their levels.

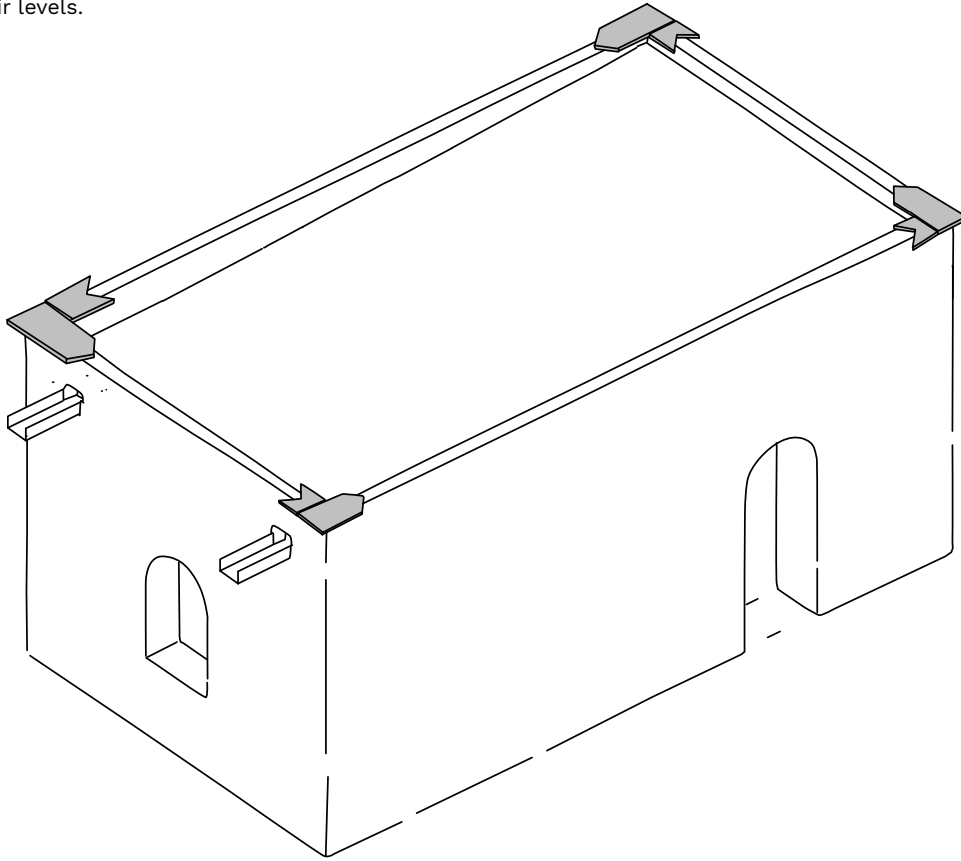

The upper surface of the parapet bricks should be scored and moistened.

The upper joints should be left empty, and filled later with cement mortar for sound fixing.

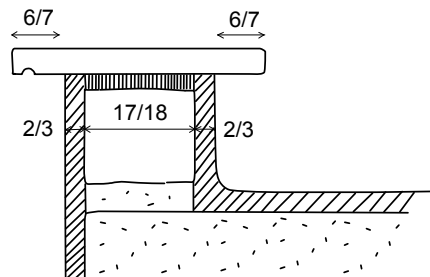
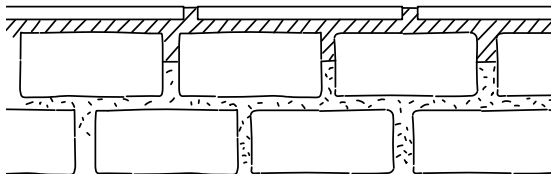

12.1 - D ★ AD

PARAPETS

PROTECTION WITH CEMENT SLABS - LAYING

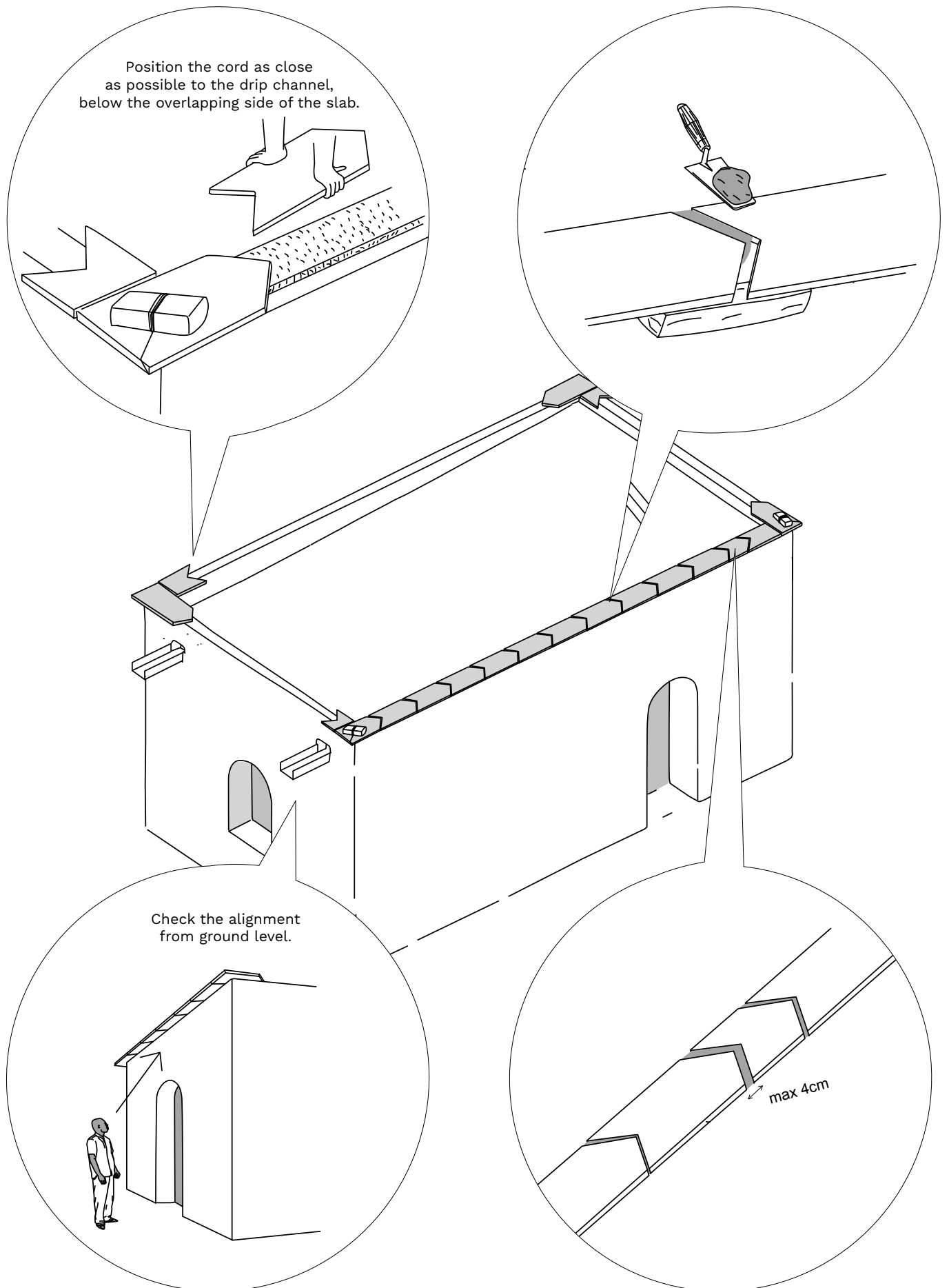

12.2 ★ AD

PARAPETS

REINFORCED CONCRETE PROTECTION

PHASE 2

12.3

BALUSTRADES

MASONRY BALUSTRADES

Masonry balustrades can be made with mud bricks or special bricks (> 1.2).
The example below is a balustrade for an accessible roof terrace:

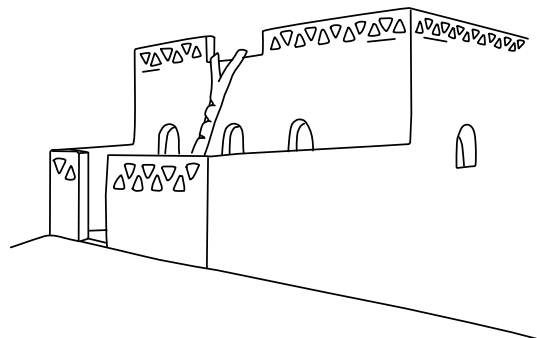
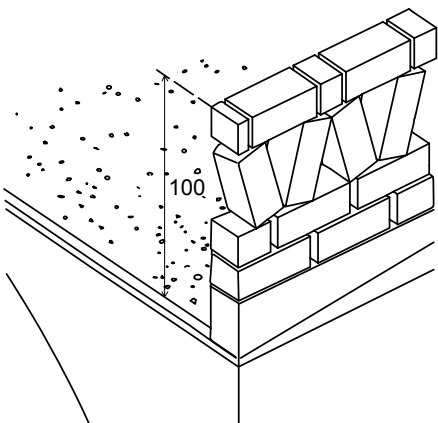
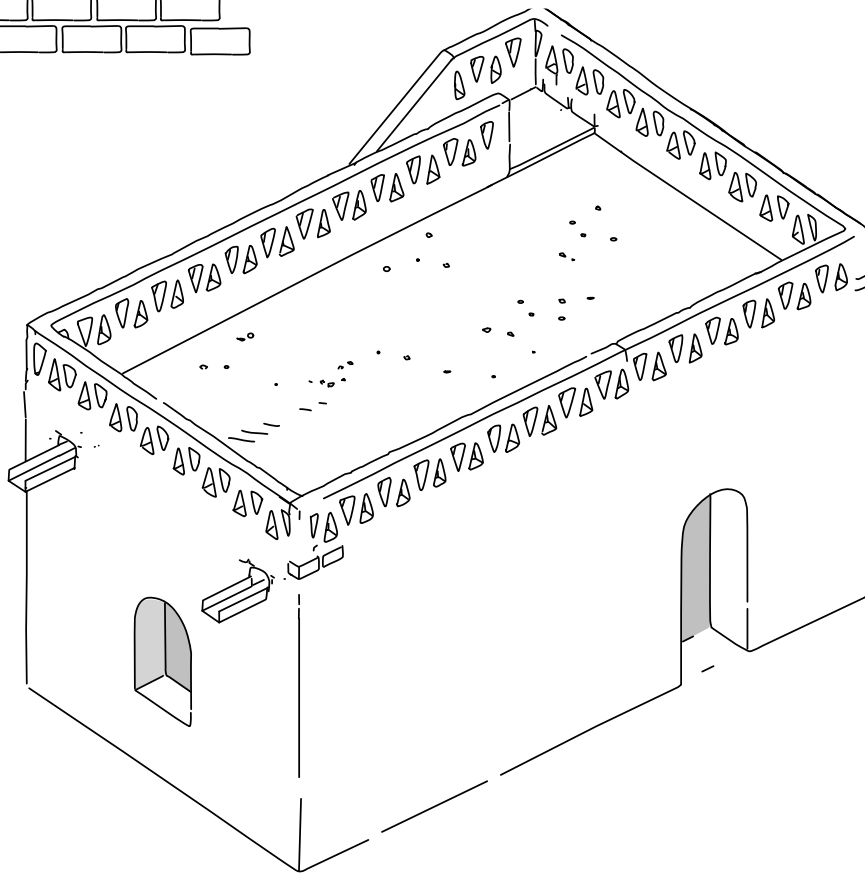
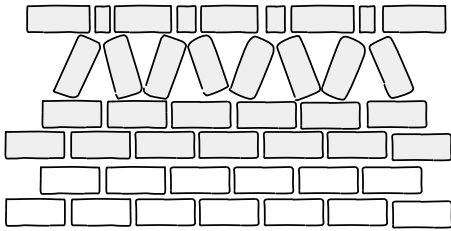

12.4 ★ AD

BALUSTRADES

METAL OR TIMBER BALUSTRADES

PHASE 2

13.1 ★ AD

EXTERIOR STAIRCASES

EXAMPLES OF EXTERIOR STAIRCASES

1

Staircase against the gable wall

The angle of the staircase can be rather steep if placed only within the width of the wall. It is better to build the first few steps past the side load-bearing wall.

REMEMBER:

The staircase must never be placed against the gutter end of the building.

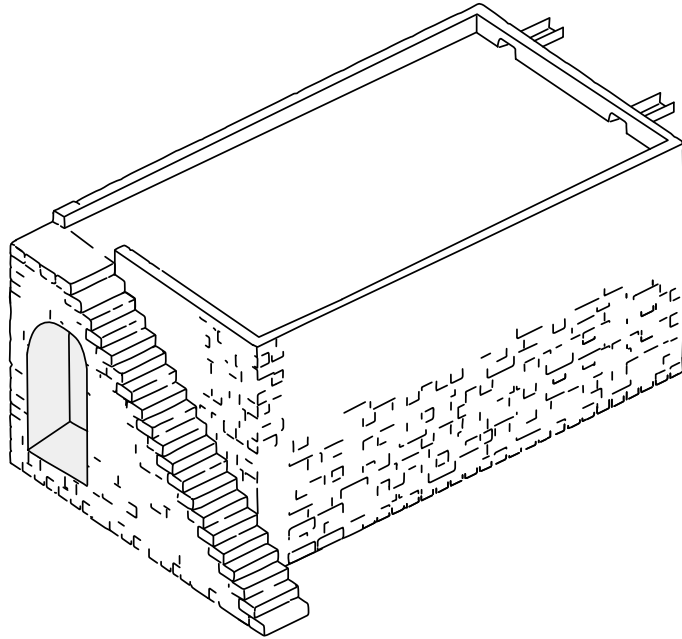

2

Staircase against the gable wall with a quarter-turn landing

It is also possible to build a staircase with a quarter-turn at the corner. This provides for a more comfortable gradient.

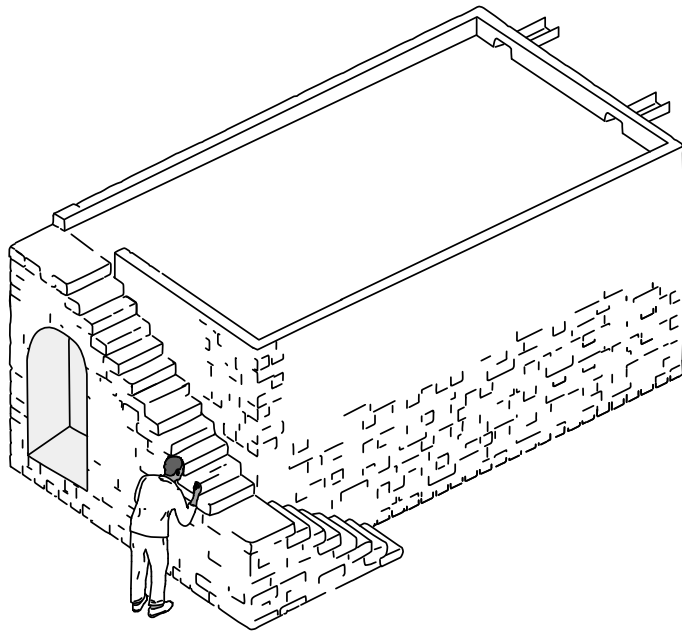

3

Staircase against a side wall

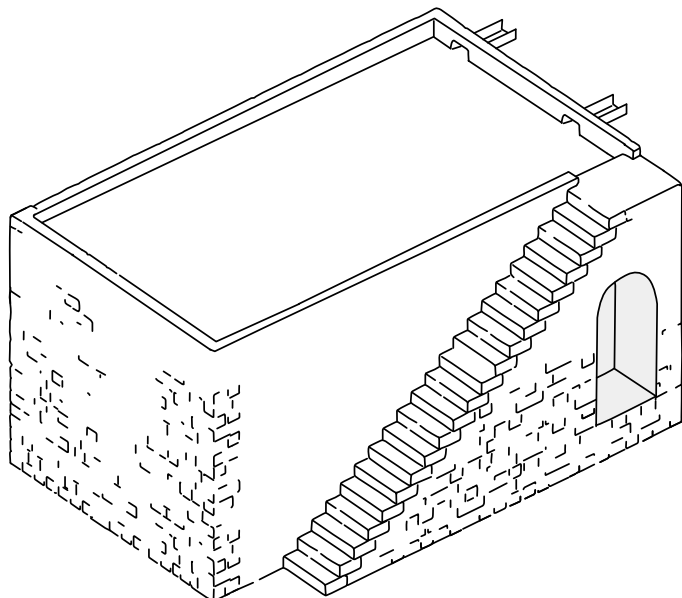

13.2 ★ AD

EXTERIOR STAIRCASES

DIMENSIONS AND TRACING

1

Step proportions

The height and width of the steps depends on the space available for the staircase. The wider the steps, the more space is needed. A staircase can be 'gentle' or 'steep'.

The recommended formula for calculating the dimensions of the steps:

$2 \times H + W = 64$ (more or less), where H=height of the step, and W = its width.

Example of a gentle staircase: W=30 cm / H= 17 cm

Example of a steep staircase: W= 24 cm / H = 20 cm

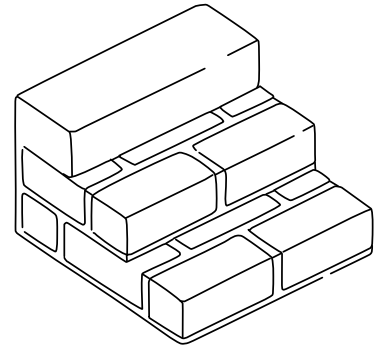

2

Calculation

It is necessary first of all to measure the height to be reached and the available length at ground level.

- length available at ground level / number of steps
= width of each step

$$\frac{\text{total height}}{\text{step height}} = \text{number of steps}$$

$$\frac{\text{length available at ground level}}{\text{number of steps}} = \text{width of each step}$$

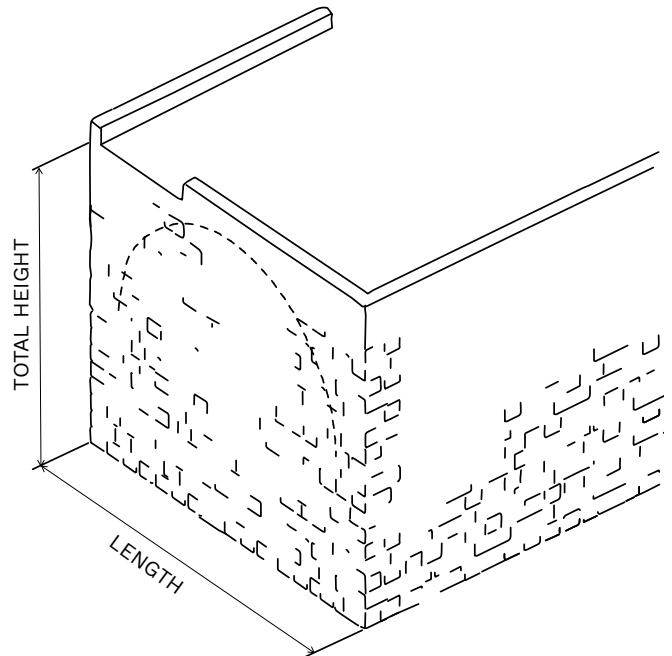

3

Tracing

The outline of the steps must be traced out on the wall before starting construction.

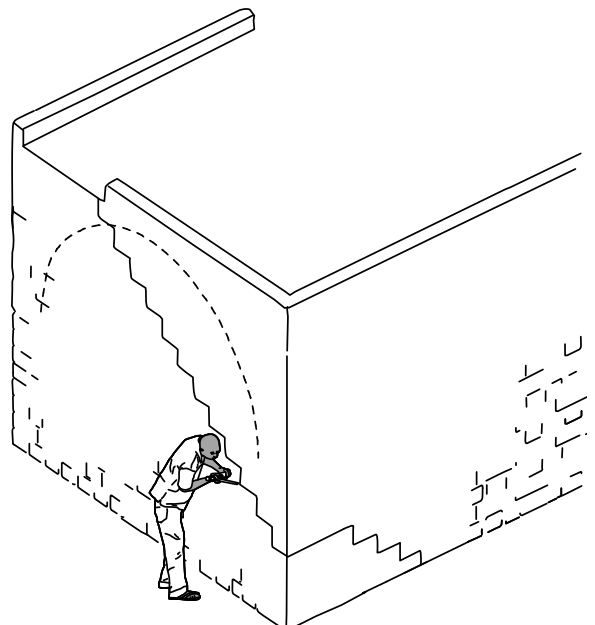
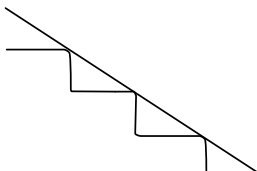

13.3 ★ AD

EXTERIOR STAIRCASES

CONSTRUCTING THE STAIRCASES

Whenever possible, the staircase should be built at the same time as the wall to which it is fixed: wall and staircase are best built together.

1

REMINDER:

If the staircase is built after construction of the building, holes should be cut into the masonry so that the staircase can be firmly attached to the wall.

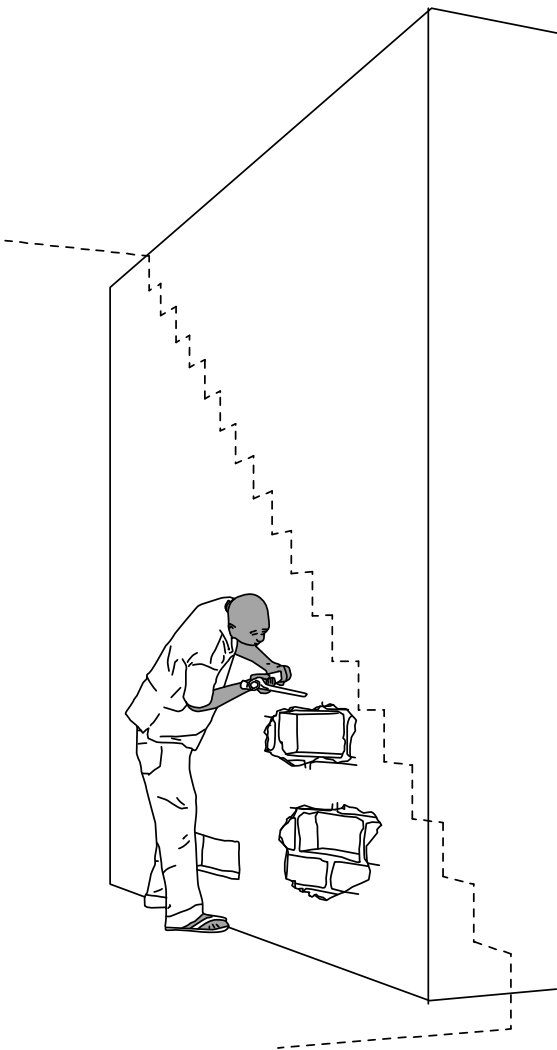

2

To economise bricks (and provide useful space), it is recommended to create alcoves (an opening + an arch) in the thickness of the staircase.

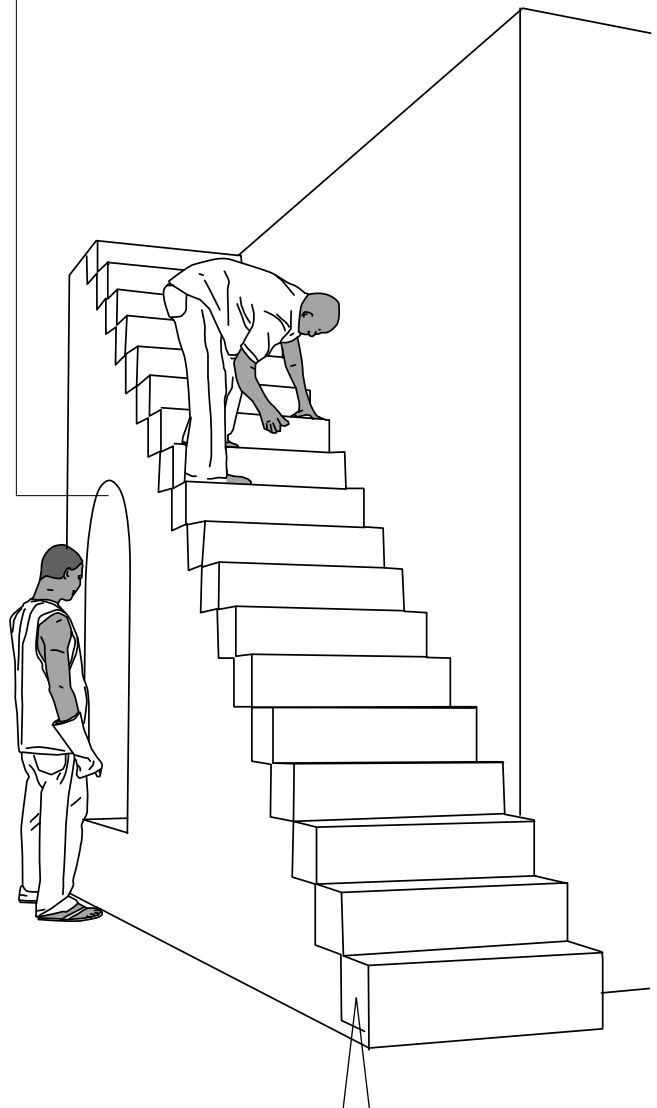

3

For really solid long-lasting steps, special bricks (> 1.2) or reinforced concrete with a render or tiles, can be used.

14.1 ★ AD
INTERNAL STAIRCASES
ONE STAGE INTERNAL STAIRCASE

PHASE 2

14.2 ★ AD
INTERNAL STAIRCASES
TWO STAGE INTERNAL STAIRCASE

PHASE 2

15.1 ★ AD
UPPER STOREY VAULT
UPPER STOREY VAULT

PHASE 2

15.2 ★ AD
UPPER STOREY VAULT
UPPER STOREY MASONRY

PHASE 2

15.3 ★ AD
UPPER STOREY VAULT
ADDING AN UPPER STOREY

PHASE 2

15.4 ★ AD
UPPER STOREY VAULT
OPENINGS IN UPPER STOREYS

PHASE 2

16.1

EXTENSIONS

EXTENDING A VAULT

PHASE 2

16.2

EXTENSIONS

ADDING A SIDE VAULT

PHASE 2

17.1

MINOR MASONRY WORKS

THICK MASONRY PARTITION WALLS

1

Plan ahead by leaving gaps during construction of the load-bearing walls.

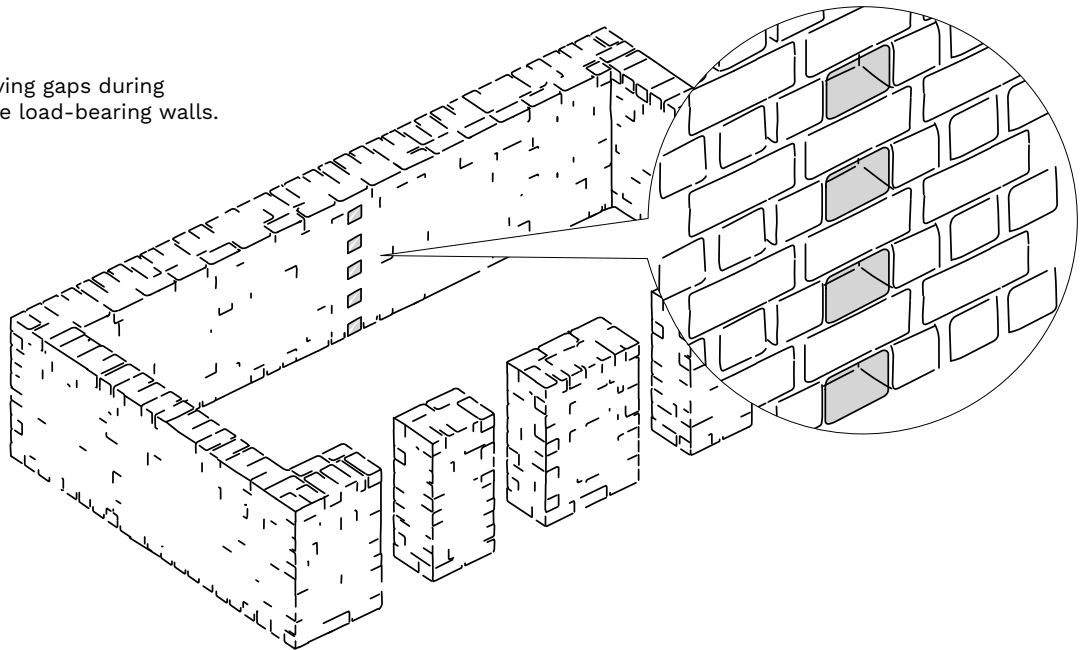

2

Clean the gaps and surfaces.
Dig and fill the foundations.

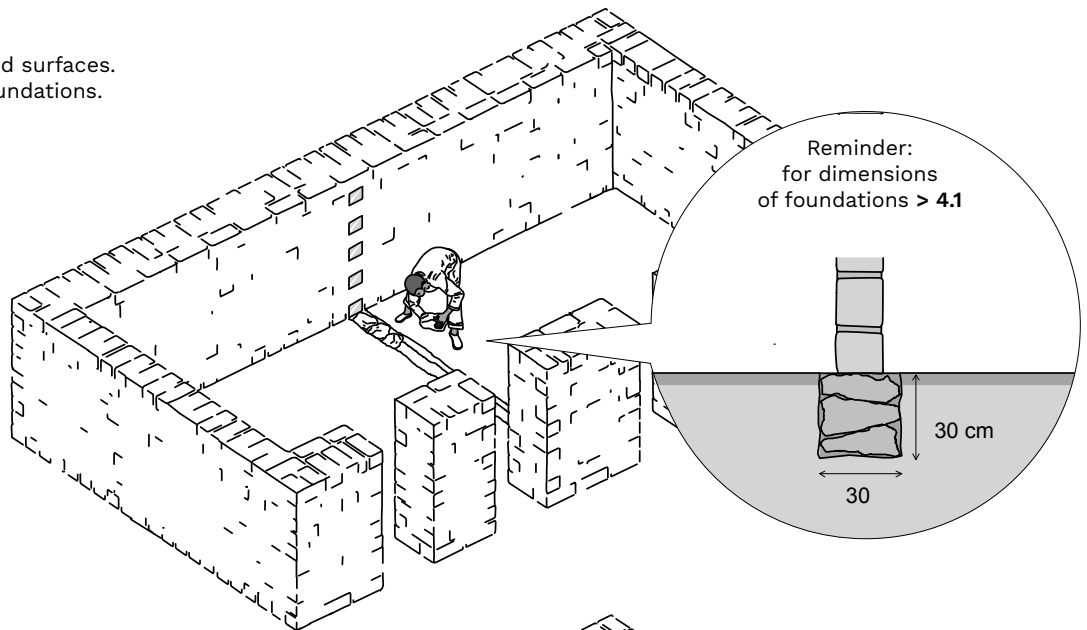

3

Build the partition wall, taking care to alternate the brick joints.

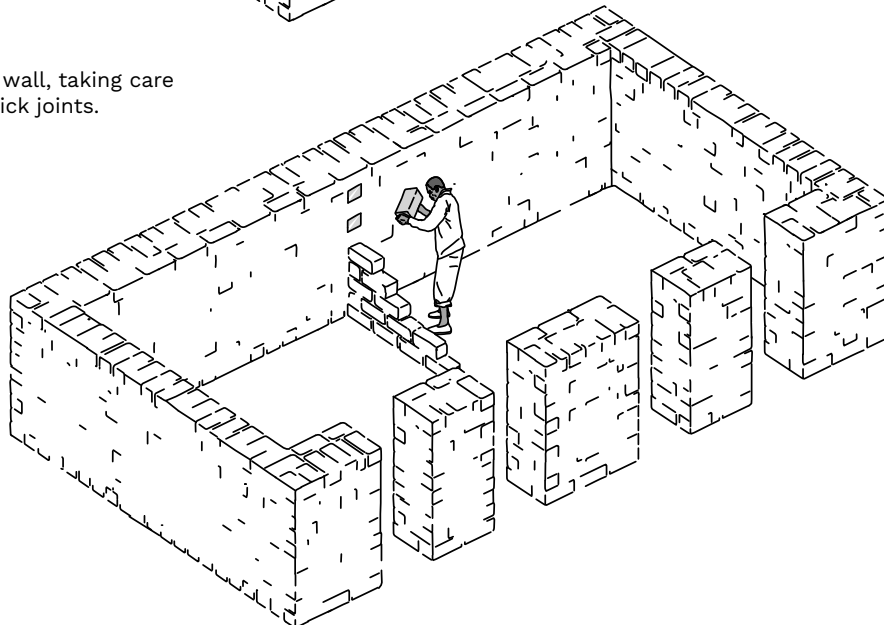

17.2

MINOR MASONRY WORKS MASONRY SHELVES

REMEMBER: Build the shelves before applying the finishes!

To make shelves out of bricks, first cut notches with a hoe in the sides of the wall. Make an arch of three bricks, trimming the centre brick so that it fits well with the side ones. Cover the bricks with earth mortar, level, and smooth.



Make 2 shelves if there is a window.

Make 3 shelves if no window.

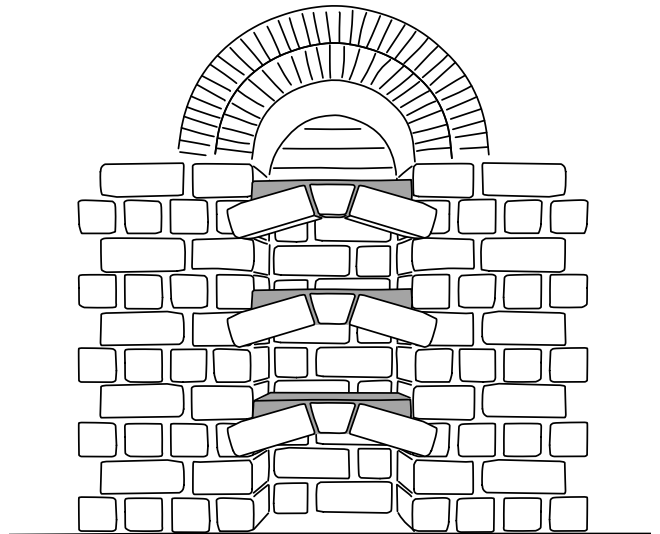
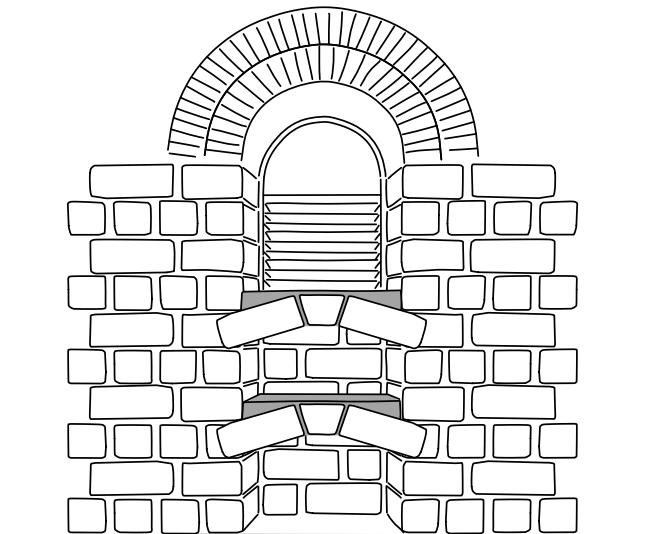

17.3 ★ AD

MINOR MASONRY WORKS

LIGHTWEIGHT PARTITIONS

In some cases, lightweight partitions can be installed:

- upper storey partitions over ground floor spaces
- for dividing up internal spaces
- built-in cupboards

Such partitions do not generally need specific foundations, and can be laid directly onto the floor.

PHASE 2

18.1 ★ AD

JOINERY

WINDOW SILLS

The placement and treatment of window sills depends on how the windows are fitted (flush to the interior or exterior wall, centred) and on the client's requirements.

They are made with mud bricks (part of the wall) and should be protected: simple or stabilised anti-erosion renders, poured or pre-fabricated concrete, tiles etc.).

1
Clean the surface.

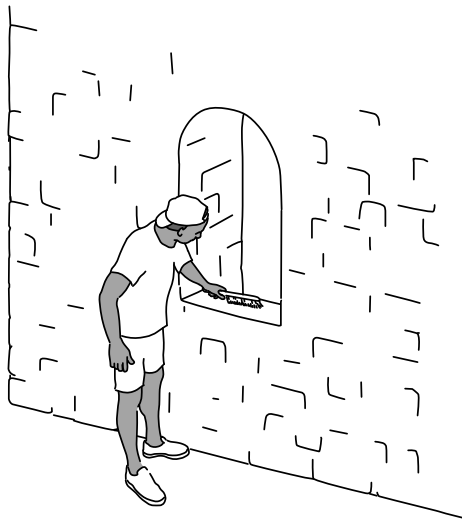

2
Check the level.

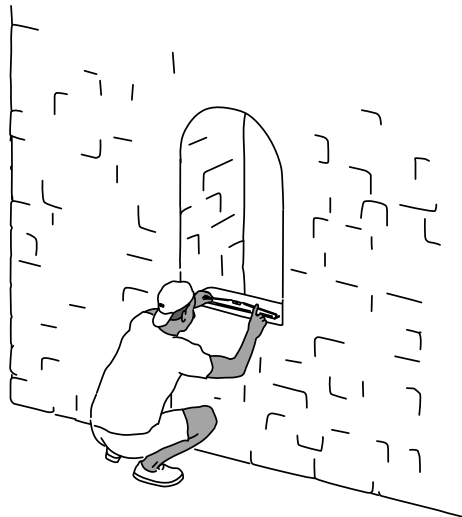

FITTING STANDARD WINDOWS (EXTERIOR)

REMINDER:

The dimensions of the openings should be checked by the fitter on-site, because they may not match exactly with those on the plans.

1

Never start the production of the windows without having checked the measurements on-site.

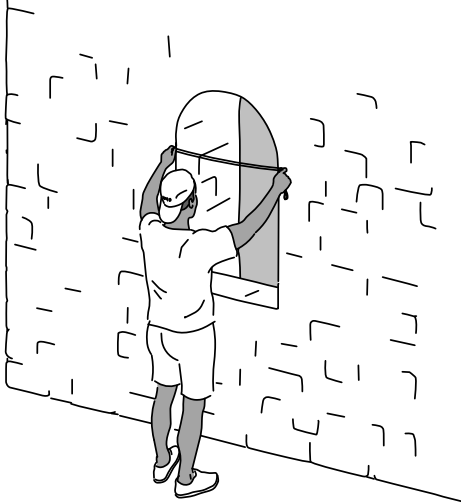

2

Cut out the notches into which the fixing cleats will be placed.

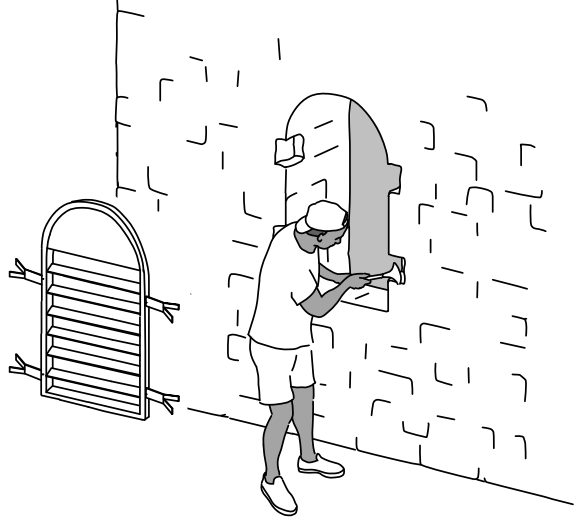

Rigid steel fixing cleats pointing towards the inside of the wall.

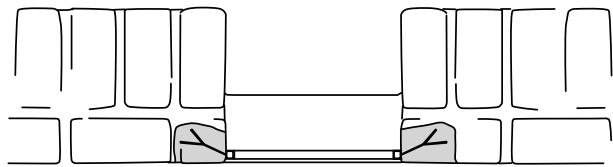
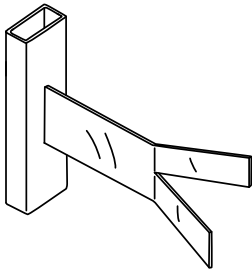

3

Moisten the notches thoroughly, then fix the cleats with cement mortar, taking care to check the level of the window frame.

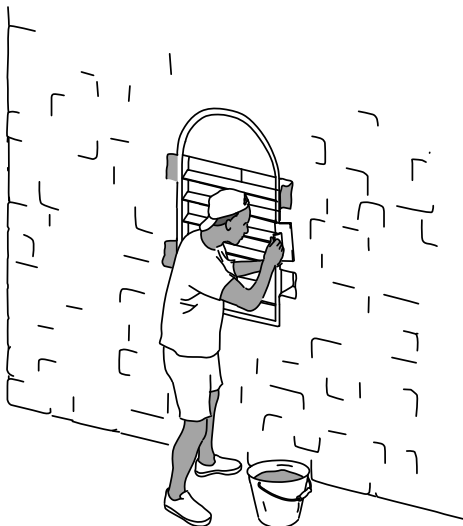

4

Cover the sill with earth or cement mortar.

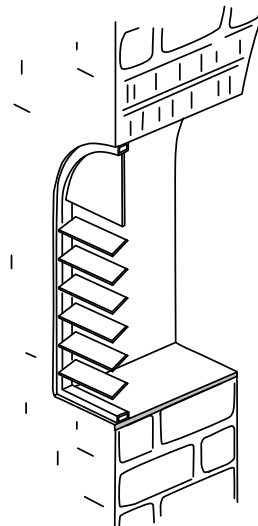

18.3 ★ AD

JOINERY

FITTING WITH A REINFORCED CONCRETE SILL

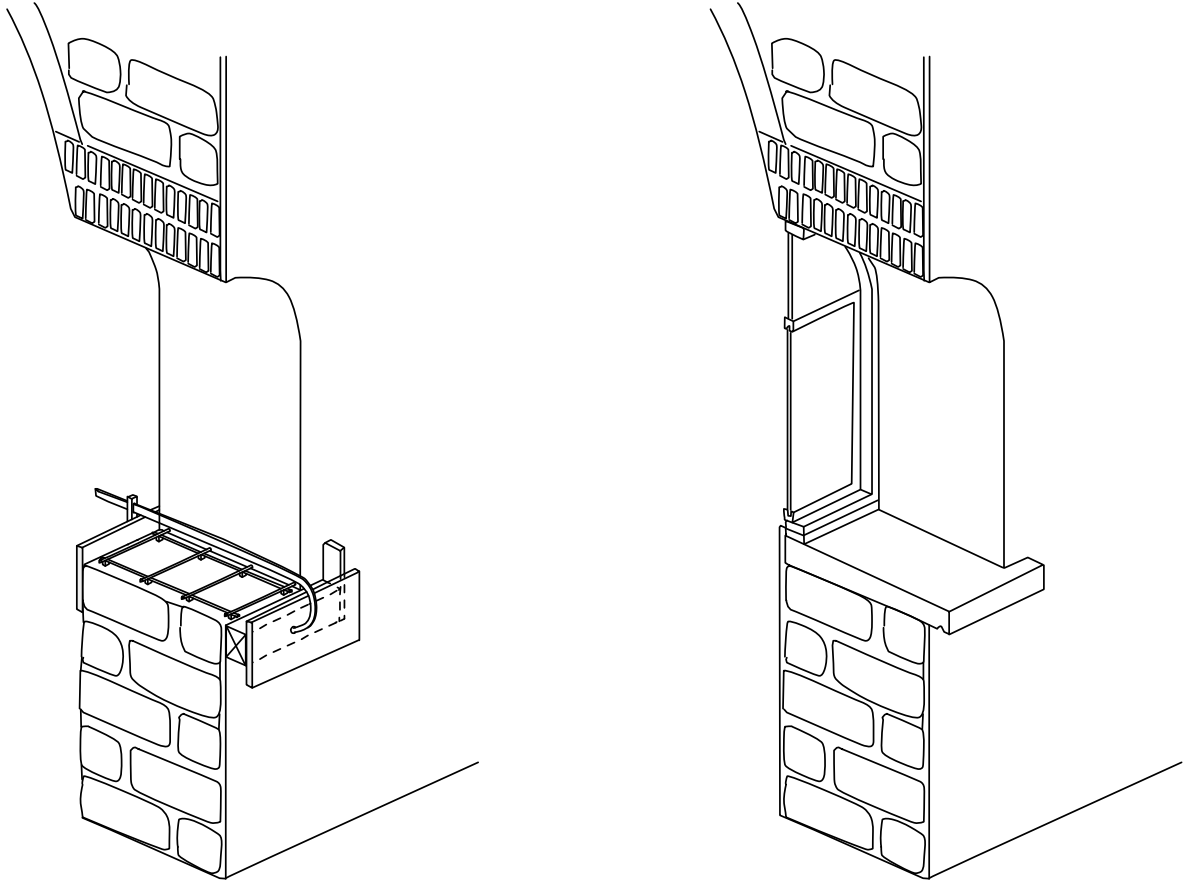

The concrete should be poured in situ with a 2% slope towards the outside and with a 6 cm overlap from the final rendered wall. Remember to include a drip channel under the overlap.

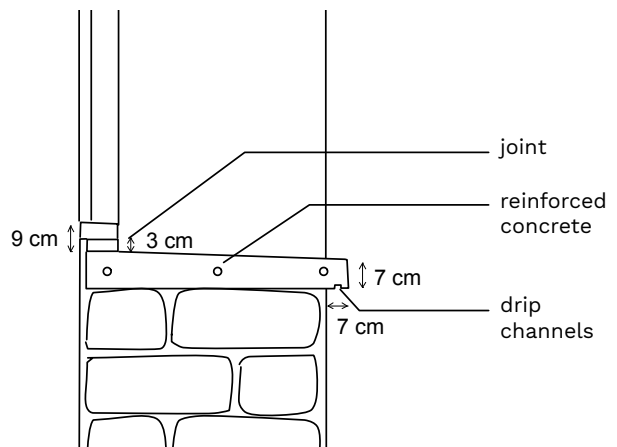

19.1 ★ AD

ELECTRICAL WORKS

CABLE DUCTS AND CHANNELS

ATTENTION: An NV artisan is NOT an electrician! Electrical work is a different skill in its own right, and we recommend that all electrical installations be made by an electrician, following the specific guidelines provided by the NV artisan!

IMPORTANT: It is easy to fit cable ducts for electrical wiring in step with construction of the walls. It is also feasible to cut channels in the completed masonry, preferably before any final render is applied.

1

Ideally, the electrician should intervene during the construction of the foundations and wall bases to fit specific cable ducts.

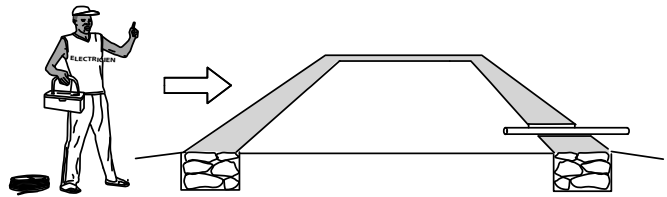

2

For cables crossing a room, fit the ducts at ground level. For fittings on the vault, as far as possible fit the ducts above the vault before construction of the buttresses / vault loading.

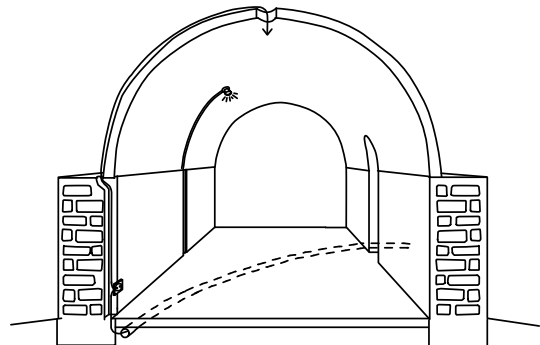

3

ATTENTION: channels in the surface of the vault should be cut vertically, and only after completion of the vault infill.

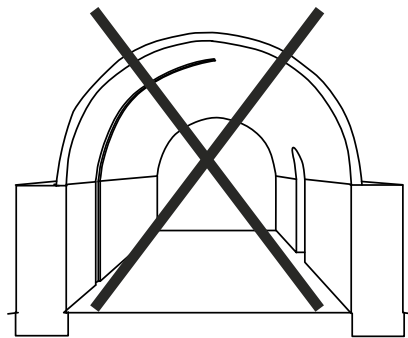
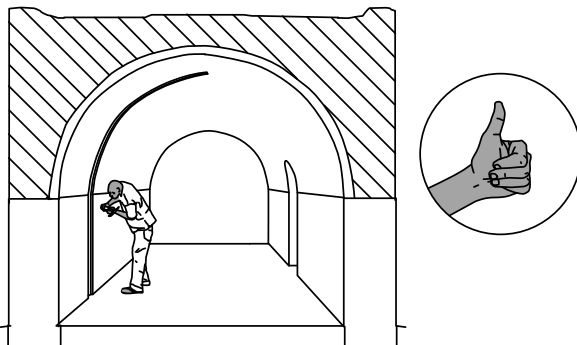

19.2 ★ AD

ELECTRICAL WORKS

CEILING LIGHTS AND FANS

1

For a light or fan at the summit of the vault, the cable duct should be fitted over the vault (outside) before addition of the vault infill. A small hole can then be made in the top of the vault, without the need for cutting any channels in its inner surface.

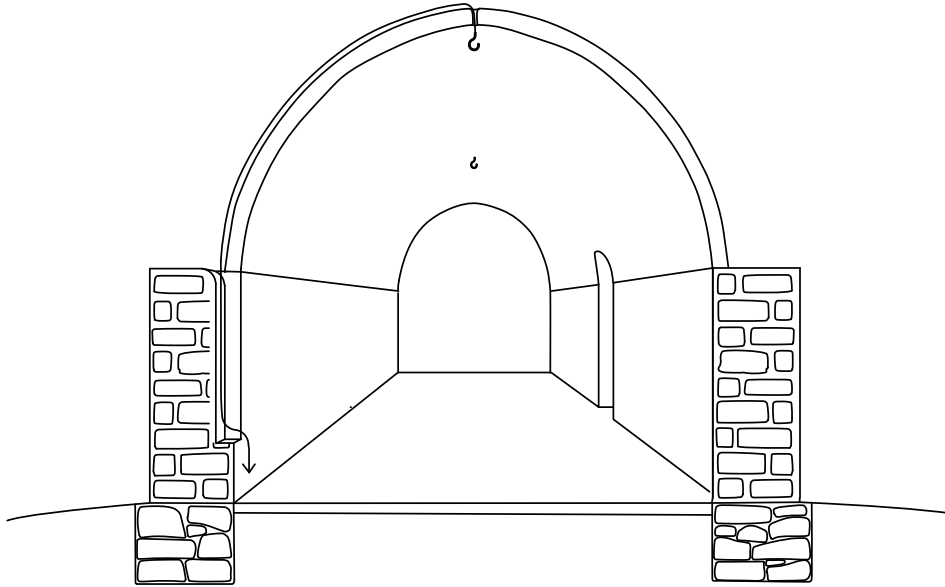

2

To fix a light fitting or ventilator to the top of the vault, make a steel cross of around 1m X 1m, with a threaded rod bolted in the centre going through the vault to attach the fitting.

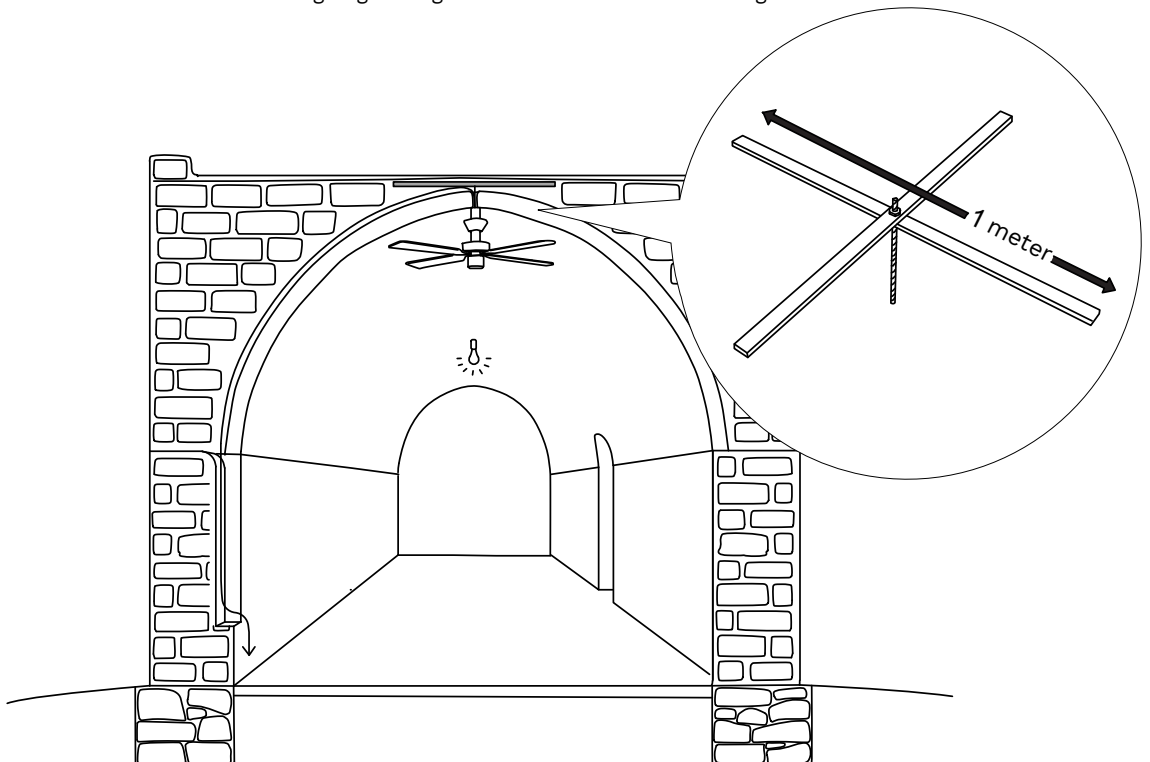

20.1 ★ AD
PLUMBING
WASTE WATER PIPE WORK

PHASE 2

20.2 ★ AD
PLUMBING
UPPER STOREY PLUMBING

PHASE 2

21.1 ★ AD

FLOORS

EXAMPLES OF FLOOR TREATMENTS

Preparation

1
Hardcore

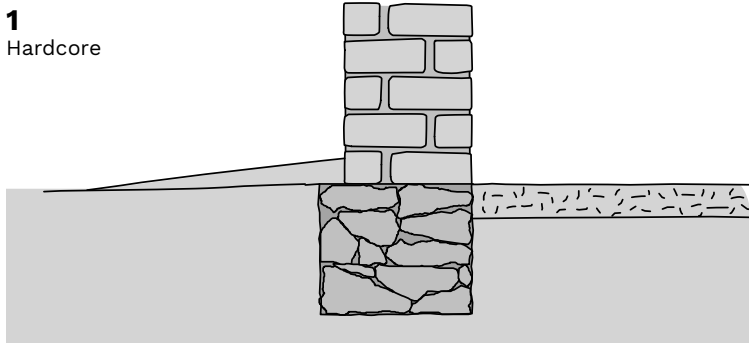

2
Stone bedding
(if ground is damp)

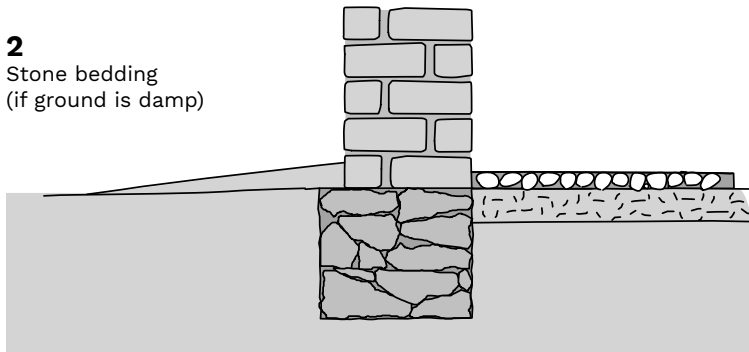

3
Plastic sheeting
(if ground is damp)

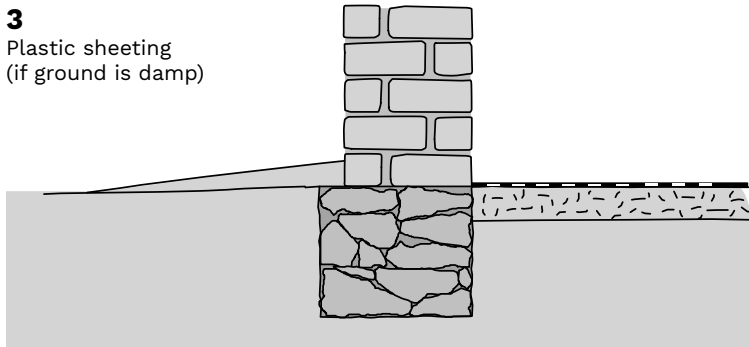

Standard solutions

4
Hardcore + compacted earth

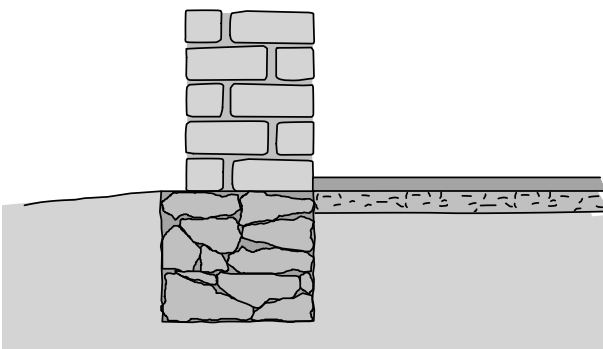

5
Hardcore + reinforced concrete slab.

The slab should be kept separate from the wall in case of differential settling.

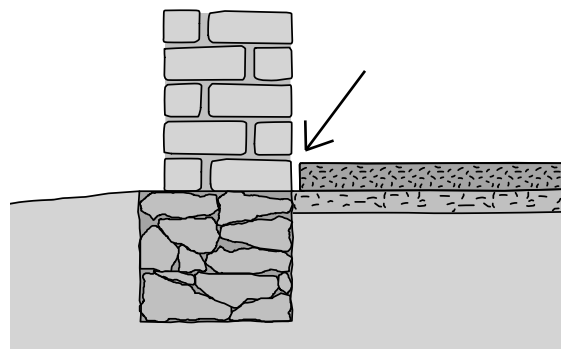

21.2 ★ AD
FLOORS
CEMENT SCREED AND TILING

PHASE 2

21.3 ★ AD

FLOORS

LOWERING INTERNAL FLOOR LEVEL

PHASE 2

22.1

RENDERS

INTRODUCTION

There are three types of render generally recommended by AVN:

- a traditional earth based render (> 22.3)
- traditional render with added bitumen (> 22.4, 22.5)
- a cement and sand render, over stony bricks (> 22.6, 22.7)

There are other types of render (earth+lime, sand+ lime etc.).
 Renders take time and skill to apply, can be costly, and must be executed with great care.
 A traditional earth render, properly applied, is an option with excellent value for money.

EXTERIOR RENDERS

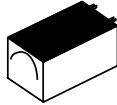
	Walls 	Roof 
NOTHING	NO!	NO!
EARTH	OK	OK
BITUMEN	OK	OK
CEMENT	OK	NO!

INTERIOR RENDERS

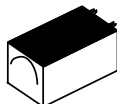
	Walls 	Vault 
NOTHING	OK	OK
EARTH	OK	OK
CEMENT	OK	NO!

22.2

RENDERS

SURFACE PREPARATION

The surfaces to be rendered must be prepared with care for the render to adhere correctly.

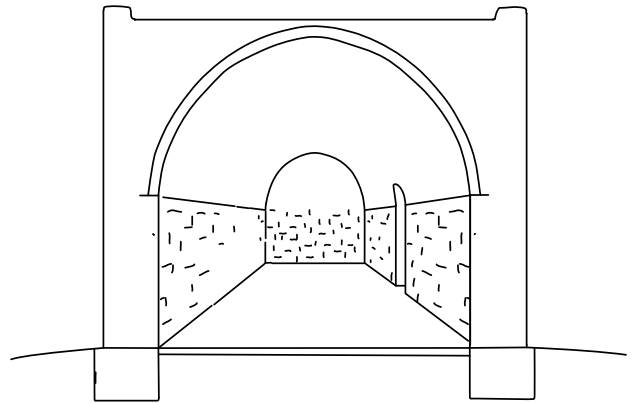
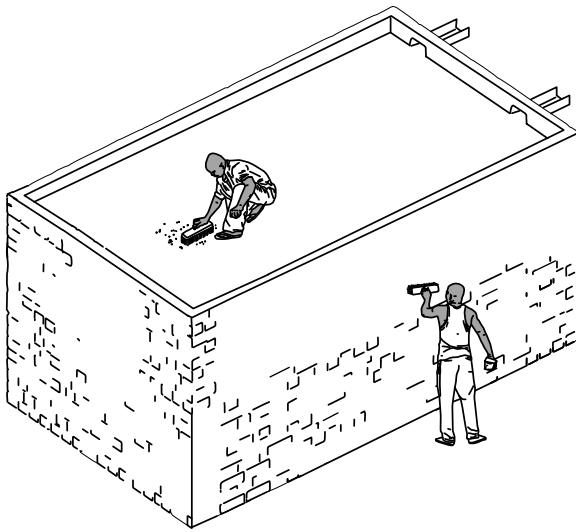

1

Use a stiff brush to clean the surface, rake out the joints a little to improve adherence. Fill any big holes.

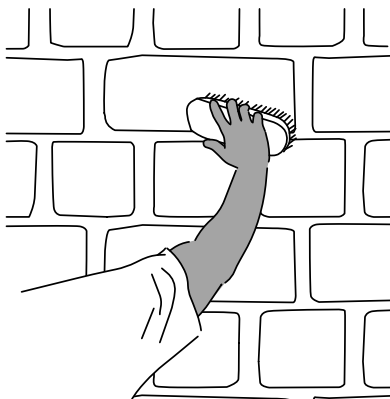

2

Fully saturate the surface with water, until it is running down the wall, to guarantee that the render will stick.

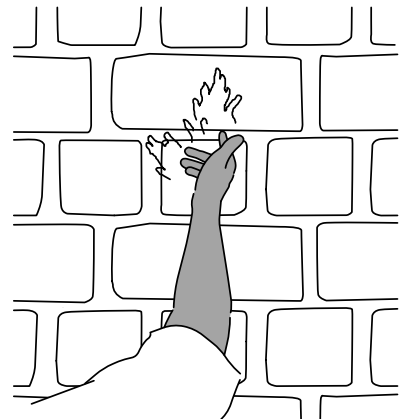

22.3

RENDERS

TRADITIONAL EARTH BASED RENDERS

Earth based renders have been used for millennia, both indoors and on exteriors of buildings. Their 'recipes' vary from one region to another, depending on the available adjuvants. Regular maintenance is needed, depending on the circumstances.

Popular adjuvants are natural stabilisers and/or vegetal fibres.

A mason working in a zone or region with which he is not familiar should identify local specialists for advice on suitable recipes.

1

It is preferable to use a mixture of clay (1 volume) and sandy earth (2-3 volumes), wet the earth thoroughly and trample on it to mix well.



2

To strengthen the render when using very clayey earth, add vegetal fibres (from rice or millet plants, chopped straw etc.): 20-30 kg per m³ of earth is a standard dosage.



3

The mixture can be stabilised to slow down the degrading of the render by the addition of natural products:
- vegetal, such as nere juice, shea butter, oil, etc.)
- animal, such as cow dung or donkey droppings.
Such stabilisers are generally used for exterior renders.

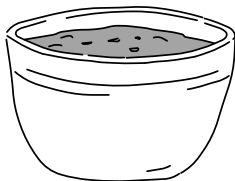

4

Wet the earth thoroughly and trample on it.



5

Cover with a plastic tarpaulin and leave the mixture to ferment for 1 - 2 weeks.

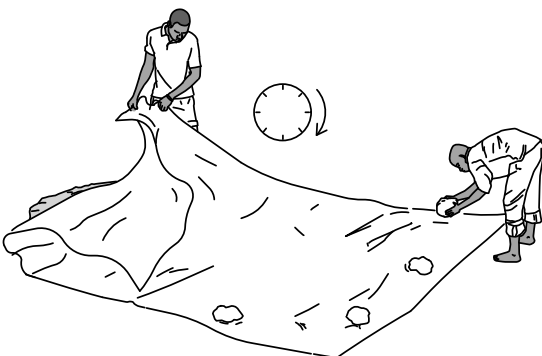

6

Apply the render by hand or with a trowel, working from the top downwards; use 1 - 3 coats depending on the earth, the techniques etc.



22.4 ★ AD





RENDERS

BITUMEN RENDER FOR EXTERNAL WALLS

EARTH - SAND -BITUMEN

Regular maintenance of buildings with a simple earth mortar is sometimes a problem. In such cases, it is better to use reinforced external renders, or mixed masonry.

RECOMMENDED DOSAGES

Bitumen	Fine sand	Earth	Waste oil	Petrol
17kg	8 wheelbarrows	1 wheelbarrow	6 litres	3 litres
				

1

Heat the bitumen in a metal container until it boils, then add the petrol and the waste oil.



2

The earth and sand should then be wetted and trampled to obtain a homogeneous sticky mortar, which is then spread on the ground at a thickness of 10-15 cm, and the bitumen poured over it.



3

Mixing

The mixture must then be trampled whilst hot, at least three times until the bitumen has completely bonded to the mortar.

IMPORTANT: the better the quality of the mix, the longer lasting the render.

ATTENTION: Wear boots, otherwise you'll get burnt!!!

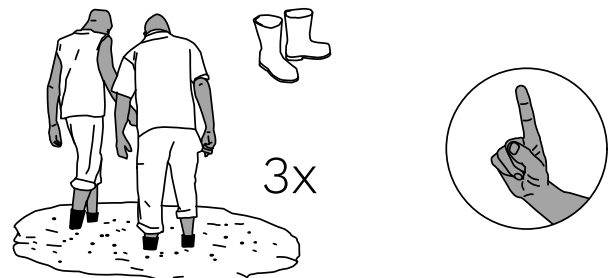

4

Application

The surface of the wall must first be prepared (> 22.2) Apply the render manually, at a thickness of around 2cm, working from the top downwards

Reminder: complete the entire wall in one session!

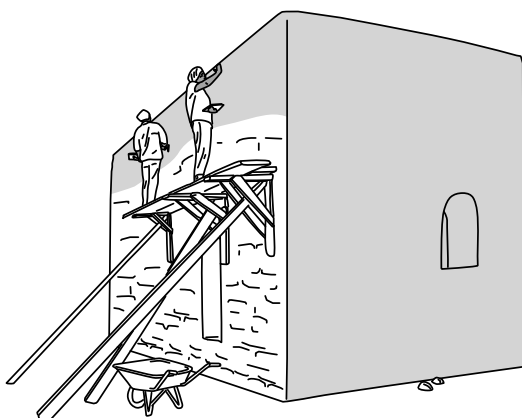

5

Finishing

Trowel the render then go over it with a sponge to obtain a regular smooth surface.



22.5 ★ AD

RENDERS







BITUMEN RENDER FOR ROOFS

EARTH - SAND - GRAVEL - BITUMEN

Regular maintenance of buildings with a simple earth mortar is sometimes a problem. In such cases, it is better to use reinforced external renders.

IMPORTANT: Never use cement renders on NV roofs.

RECOMMENDED DOSAGES

Bitumen	Fine sand	Gravel	Earth	Waste oil	Petrol
17kg	3 wheelbarrows	5 wheelbarrows	1 wheelbarrow	6 litres	3 litres
					

1

Preparation

Follow the same steps as for bitumen render for walls (> 22.4)

IMPORTANT: Gravel is added to reduce the drumming noise of rain on the roof.

Make sure that the mix is not too liquid, otherwise it settles in the hollows and fails to dry properly. The long term viability of the roof terrace depends on how well the render has been mixed.

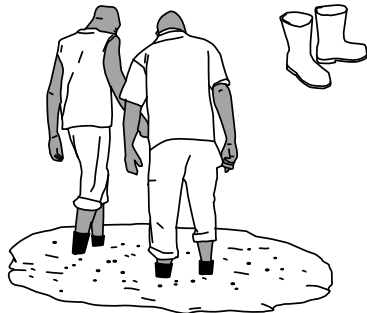

2

After preparing the roof surface (> 22.2), spread 4-5 cm thick clumps of the render mortar over the roof.

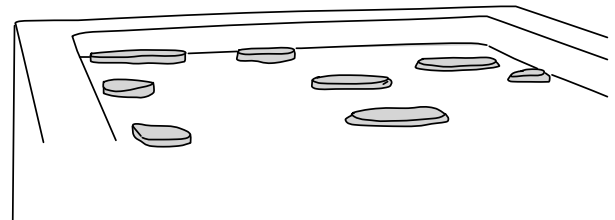

3

Spread the mortar out from the clumps and trowel the render with a float.

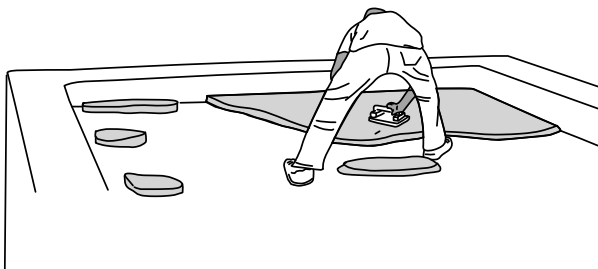

4

The next day, wet the render thoroughly and go over it again with a trowel or float, smoothing out any cracks that may have appeared.

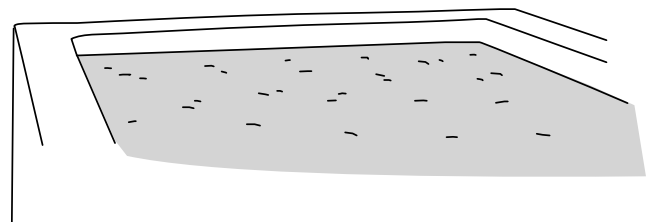

22.6 ★ AD

RENDERS

SAND-CEMENT RENDER FOR EXTERNAL WALLS OF STONY BRICKS



Sand-cement renders are for the walls only.

Never use them on roofs!

To avoid moisture rising in the walls, a damp-proof course bitumen or plastic sheeting should have been inserted between the foundations and the base of the walls, at the start of construction.

- 1**
After preparing the wall surface (> 5.7), apply a semi-liquid adhesive coat of around 5mm.

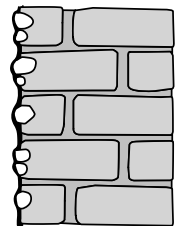

RECOMMENDED DOSAGES

Cement	Fine sand	Water
50 kg	10 x 10 L	4 X 10 L
		



- 2**
Wait until the first coat is dry before starting, then wet the surface and apply the main coat, about 20mm thick.

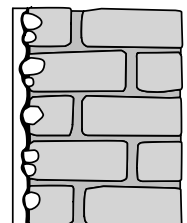

RECOMMENDED DOSAGES

Cement	Fine sand	Water
50 kg	12,5 x 10 L	3 X 10 L
		



- 3**
Wait until the second coat is dry before starting. Then wet the surface and project the finishing Tyrolean type coat, around 5mm thick.

RECOMMENDED DOSAGES

Cement	Fine sand	Water
50 kg	14 x 10 L	3 X 10 L
		

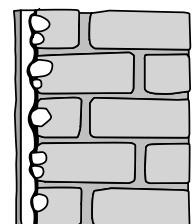
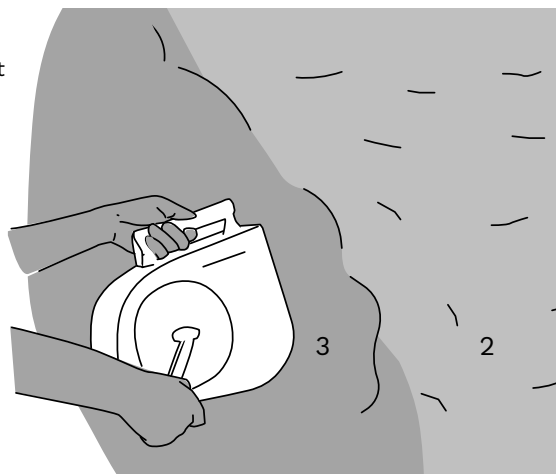

22.7 ★ AD

RENDERS

SAND-CEMENT RENDER FOR INTERIOR WALLS

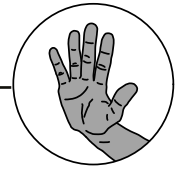

REMINDER: Never use cement render on the vault ceiling!



A cement render can be used on the interior walls if the client wishes - it provides better protection against scuffs and knocks, and a better base for paint.

1
After preparing the wall surface (> 5.7), apply a semi-liquid adhesive coat of around 5mm.

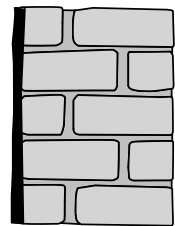
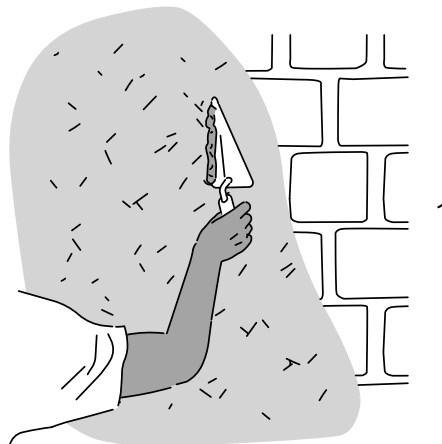

RECOMMENDED DOSAGES

Cement	Fine sand	Water
50 kg	10 x 10 L	4 X 10 L
		



2
Wait until the first coat is dry before starting, then wet the surface and apply the main coat, about 20mm thick.

RECOMMENDED DOSAGES

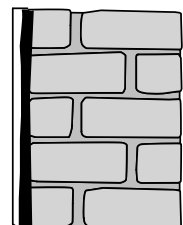
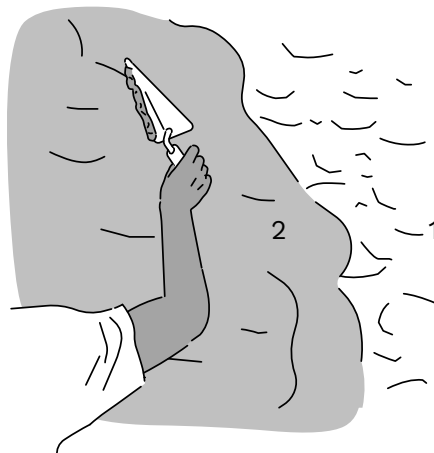

Cement	Fine sand	Water
50 kg	12,5 x 10 L	3 X 10 L
		



end with a clean finish!

3
Wait until the second coat is dry before starting. Then wet the surface and trowel on the finishing coat, around 5mm thick.

RECOMMENDED DOSAGES

Cement	Fine sand	Water
50 kg	14 x 10 L	3 X 10 L
		

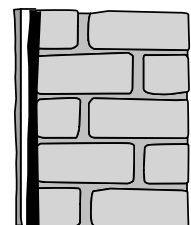
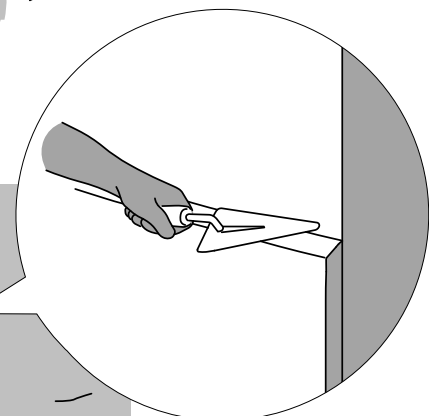
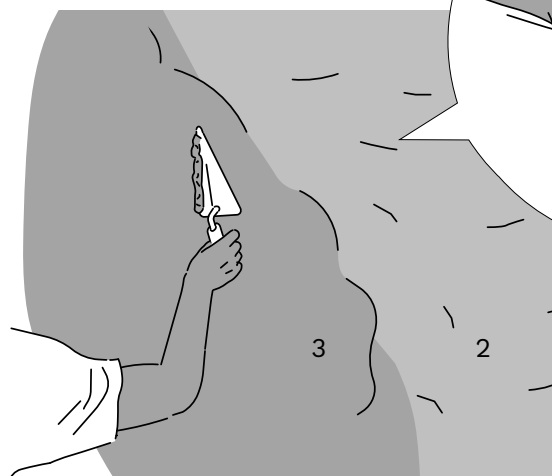

22.8 ★ AD
RENDERS
WALL TILING

PHASE 2

23.1

PAINT



INTERIOR WHITEWASH AND PAINTS

1

LIME WHITEWASH

Apply the whitewash on the walls and vault ceiling.

RECOMMENDED DOSAGES

Lime	Water	Salt
5 kg	12,5 L	2 kg
		

2

STANDARD PAINTS

Any type of paint can be applied to sand-cement renders. On an earth-based render, acrylic and latex-based paints can give good results.

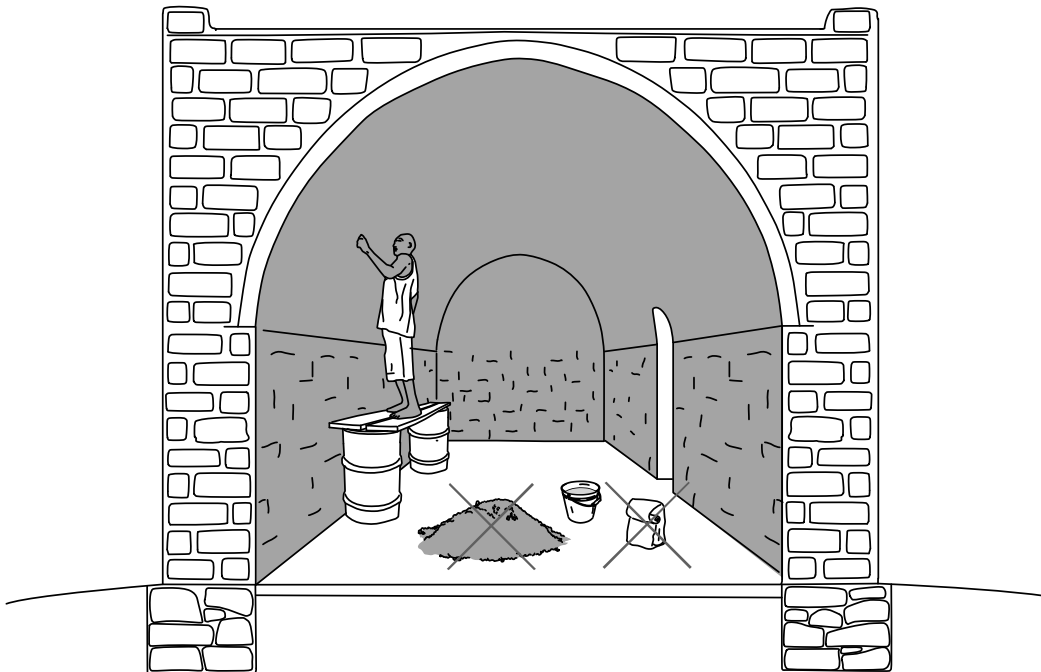

23.2 ★ AD
PAINTS
EXTERNAL PAINTWORK

PHASE 2



© La Voûte Nubienne
www.lavoutenubienne.org

Edition 2018 by USUS Architects.
Led by Mathieu Hardy, architect.
Under the supervision of Thomas Granier, General Director, Founder.